

# **500E**

**INCLUDING: OPERATION, INSTRUCTION, INSTALLATION, MAINTENANCE AND PARTSBOOK**

**IMPORTANT: READ THIS MANUAL CAREFULLY BEFORE INSTALLING, OPERATING OR  
SERVICING THIS TOOL.**

## **BEEF BRISKET SAW - ELECTRIC**

### **TOOL DATA**

MODEL: KENTMASTER 500E  
ASSEMBLY NO: 1050000  
TYPE: ELECTRICAL OPERATED  
NET WEIGHT: 80 LB (36 KG)  
MOTOR HORSEPOWER: 1HP / 50Hz, 60Hz

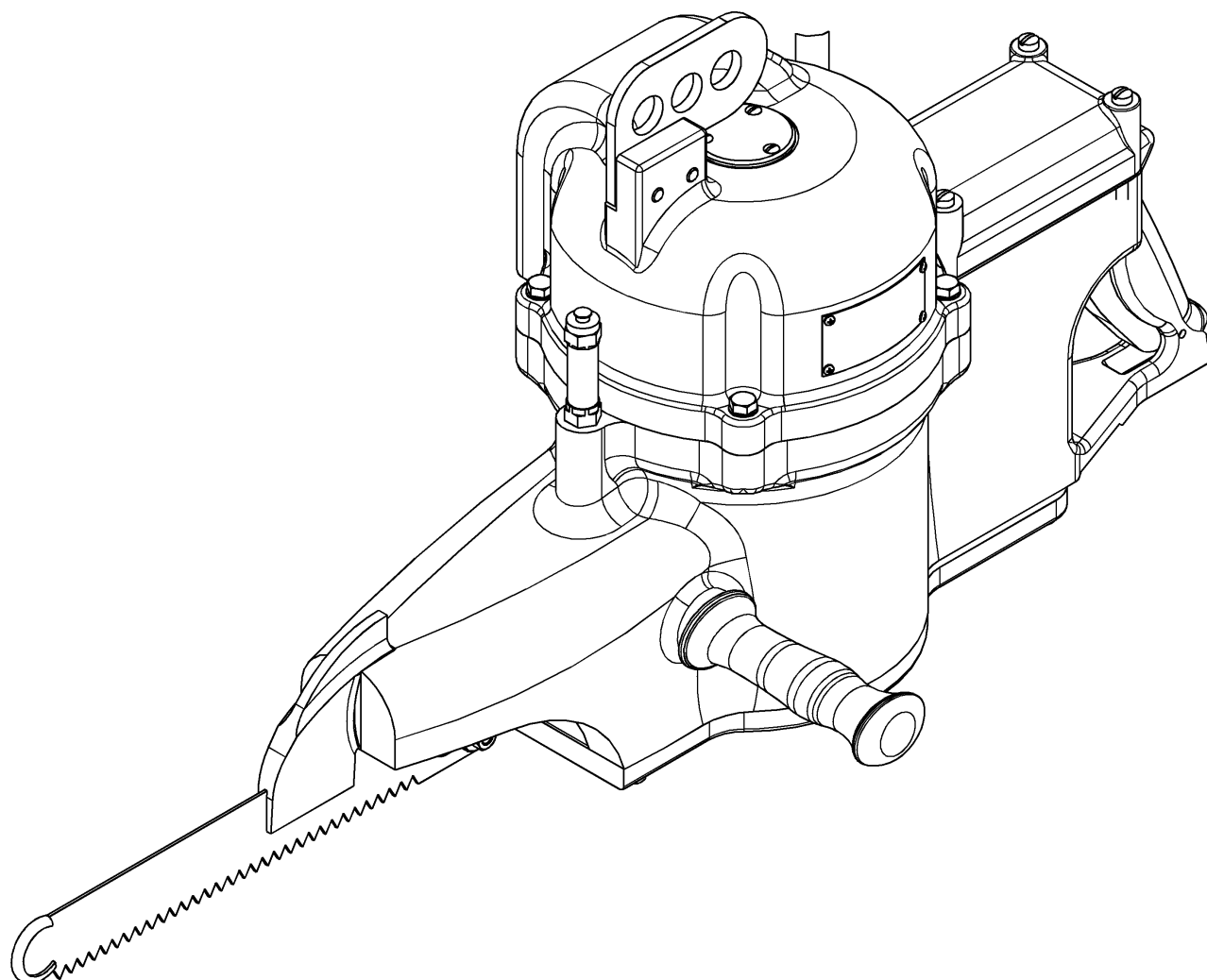

 **WARNING** = Hazards or unsafe practices which could result in severe personal injury, death or substantial property damage.

 **CAUTION** = Hazards or unsafe practices which could result in minor personal injury, product or property damage.

 **NOTICE** = Important installation, operation or maintenance information.

## **OPERATING AND SAFETY INSTRUCTIONS**

 **WARNING** DO NOT OPERATE THIS TOOL UNTIL YOU HAVE READ AND UNDERSTOOD THE SAFETY INSTRUCTIONS AND OPERATING MANUALS.

 **WARNING** DO NOT OPERATE THIS TOOL UNTIL YOU HAVE RECEIVED TRAINING IN THE HANDLING, OPERATION AND USE OF THIS TOOL.

 **WARNING** STOP USING A MALFUNCTIONING OR DEFECTIVE TOOL IMMEDIATELY. REPORT ANY PROBLEMS OR DEFECTS TO YOUR SUPERVISOR FOR REMOVAL OF THE TOOL FROM SERVICE.

 **WARNING** DO NOT ATTEMPT TO REPAIR THE TOOL YOURSELF.

 **WARNING** DO NOT ALLOW UNAUTHORIZED PERSONS TO USE TOOL.

 **WARNING** REMOVE AND DISCONNECT POWER FROM THE TOOL WHEN TOOL IS LEFT UNATTENDED OR IS NOT IN USE.

 **WARNING** NEVER TIE DOWN, BYPASS, ALTER OR MODIFY THE ACTIVATING SWITCHES OR TRIGGERS OF THIS TOOL.

 **WARNING** NEVER MAKE ALTERATIONS OR MODIFICATIONS TO THIS TOOL.

 **WARNING** BE CONSTANTLY AWARE AND ALERT FOR UNSAFE CONDITIONS AND REPORT THEM IMMEDIATELY TO YOUR SUPERVISOR.

 **WARNING** NEVER PLACE YOUR HAND OR ANY PART OF YOUR BODY IN THE CUTTING PATH OF THE TOOL.

 **WARNING** NEVER ALLOW ANYONE ELSE TO PLACE THEIR HANDS OR ANY PART OF THEIR BODY IN THE CUTTING PATH OF THE TOOL.

 **WARNING** DO NOT ACTIVATE CONTROL SWITCHES OR TRIGGERS OF THIS TOOL UNLESS YOU INTEND TO TEST OR OPERATE THIS TOOL.

 **WARNING** DO NOT USE THIS TOOL FOR ANY PURPOSE OTHER THAN IT'S INTENDED PURPOSE.

 **CAUTION** WHEN OPERATING THIS TOOL WEAR THE PROTECTIVE GEAR AND SAFETY EQUIPMENT SUPPLIED TO YOU.

 **WARNING** THE NOISE EMISSION (SOUND PRESSURE LEVEL) AT THE WORKSTATION MAY EXCEED 80 dB (A). EAR AND SOUND PROTECTION GEAR IS REQUIRED.

## OPERATING INSTRUCTIONS

**⚠ WARNING ONLY TRAINED PERSONNEL ARE TO OPERATE THIS TOOL.**

1. TO ENSURE TOOL IS OPERATING PROPERLY, PERFORM FOLLOWING STEPS AT START OF EACH SHIFT:
  - MAKE SURE TOOL MOVES UP AND DOWN FREELY WHILE HANGING FROM BALANCER OVERHEAD.
  - WITH POWER TO TOOL TURNED ON, TEST TRIGGER FOR PROPER OPERATION.
2. TO PERFORM WORK, HOLD TOOL FIRMLY AT BOTH HANDLES. SQUEEZE TRIGGERS TO ACTIVATE TOOL.
3. POSITION TOOL AND PERFORM CUTTING OPERATION.

### BLADE REMOVAL AND CLEANING.

**⚠ WARNING ALWAYS DISCONNECT POWER SUPPLY FROM TOOL BEFORE INSTALLING OR REMOVING BLADE FROM TOOL.**

**⚠ WARNING ALWAYS WEAR WIRE MESH GLOVES WHEN INSTALLING OR REMOVING BLADE FROM TOOL.**

1. REMOVE NUT AND BOLT (ITEM NO. 2, 4, FIG. NO. 1).
2. REMOVE BLADE (ITEM NO. 1, FIG. NO. 1).
3. CLEAN ALL PARTS REMOVED WITH SOAP AND WATER.
4. SHARPEN OR REPLACE BLADES WHEN NECESSARY.
5. REASSEMBLE IN REVERSE ORDER.

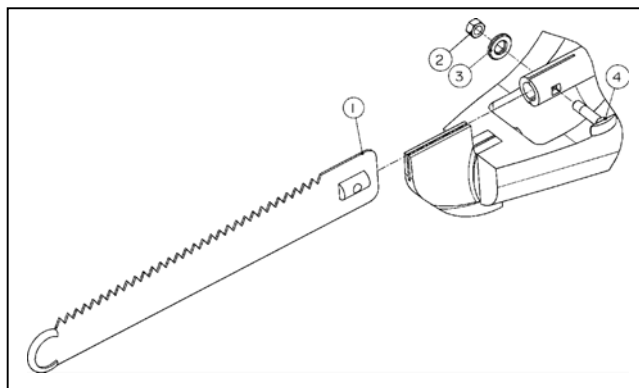

**Figure 1 MODEL 500E – BLADE REPLACEMENT**

### SERVICE

1. KEEP GOOD RECORDS OF ALL SERVICE ACTIVITY AND INCLUDE TOOL IN PREVENTIVE MAINTENANCE PROGRAM.
2. USE ONLY GENUINE KENTMASTER REPLACEMENT PARTS TO ASSURE PROPER PERFORMANCE OF TOOL.
3. CONTACT THE KENTMASTER SUPPLIER NEAREST YOU FOR PARTS AND CUSTOMER SERVICE INFORMATION.



## **INSTALLATION INSTRUCTIONS**



### **WARNING**

**ALL ELECTRICAL WIRING MUST BE DONE BY A LICENSED ELECTRICIAN IN ACCORDANCE WITH THE NATIONAL, STATE AND LOCAL ELECTRICAL CODES. (REFER TO NAMEPLATE ON TOOL FOR PROPER POWER CONFIGURATION).**

1. A BALANCER IS REQUIRED FOR OPERATION AND USE OF THIS TOOL. WEIGHT OF TOOL MUST FALL WITHIN WEIGHT RANGE OF BALANCER
2. INSTALL BALANCER ABOVE WORK AREA. BALANCER MUST HAVE SUFFICIENT VERTICAL TRAVEL SO OPERATOR CAN REACH ENTIRE WORK AREA WITH TOOL WITHOUT STRAIN
3. ADJUST BALANCER ACCORDING TO THE OPERATOR'S PREFERENCE AND COMFORT.



### **WARNING**

**WE STRONGLY SUGGEST THAT AN ADDITIONAL SAFETY CHAIN BE USED TO CHAIN BALANCER TO OVERHEAD TROLLEY. THIS ADDITIONAL MEASURE OF SAFETY WILL HELP REDUCE INJURIES.**

## **MAINTENANCE**



### **WARNING**

**ONLY TRAINED AND QUALIFIED PERSONNEL ARE TO PERFORM MAINTENANCE AND SERVICE TO THIS TOOL.**

**OIL LUBRICATION:** THE FAT OF THE CARCASS PROVIDES SUFFICIENT LUBRICATION FOR THE BLADE GUIDES AND OIL LUBRICATION OF BLADE IS NOT NECESSARY WHEN MACHINE IS IN OPERATION.

SAW SHAFT REQUIRES CONTINUOUS LUBRICATION. VERIFY OILER CUP AT THE END OF EACH SHIFT AND ENSURE THAT THE OILER CONTAINS LIGHT-WEIGHT, FOOD-GRADE OIL, ENOUGH TO COVER BOTTOM OF OILER CUP.

**RECOMMENDED LUBRICANT CAN BE PURCHASED FROM "KENTMASTER MFG., CO., INC."**

# PARTS BOOK

## "500E" MAIN ASSEMBLY

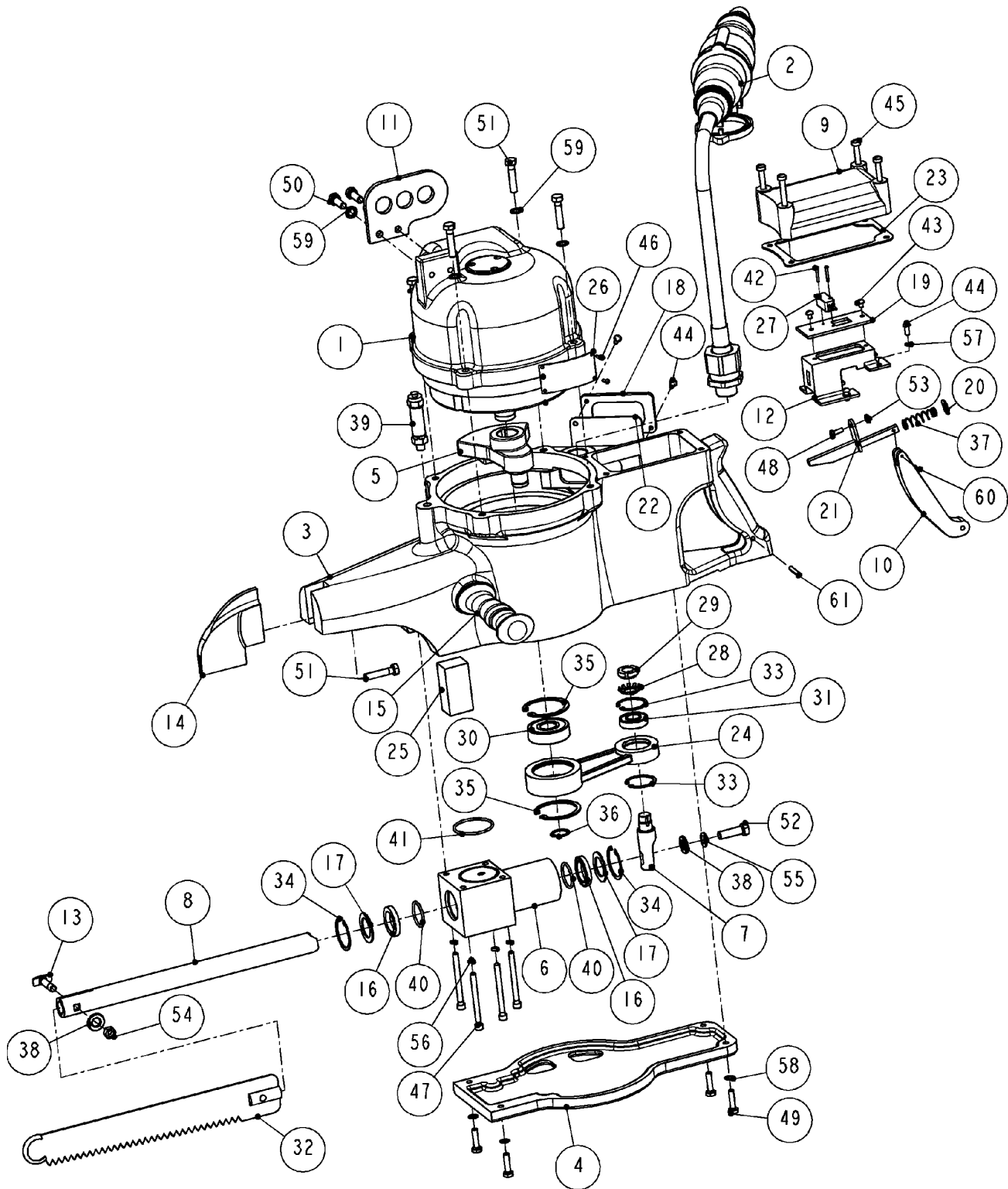

**Figure 2 MODEL "500E"**

1050000: 500E - BRISKET SAW							
ITEM	PART #	DESCRIPTION	QTY	ITEM	PART #	DESCRIPTION	QTY
1	10512__	MOTOR ASSEMBLY <b>OPTIONS</b>	1	31	3601200	BEARING	1
2	1002420	POWER CORD ASSEMBLY, NON 42V	1	32	4100170	BLADE, 13.6" LONG	1
	1002430	POWER CORD ASSEMBLY, 42V	1	33	5001370	RETAINING RING	2
3	1052010	HOUSING	1	34	5001500	RETAINING RING	2
4	1052040	BOTTOM COVER	1	35	5002060	RETAINING RING	2
5	1052120	BALANCE	1	36	5100780	RETAINING RING	1
6	1052140	GUIDE - SAW SHAFT	1	37	6000620	SPRING	1
7	1052150	SHAFT - CONNETING ROD	1	38	6001660	WASHER	2
8	1052220	SAW SHAFT	1	39	7236030	OILER	1
9	1052380	COVER	1	40	7681220	O-RING	2
10	1052390	TRIGGER	1	41	7681330	O-RING	1
11	1052420	HANGER	1	42	8023060	SCREW	2
12	1052430	BRACKET	1	43	8029020	SCREW	2
13	1052640	STEP BOLT	1	44	8029040	SCREW	6
14	1052680	BLADE GUIDE	1	45	8071200	SCREW	4
15	1052710	FORWARD HANDLE	1	46	8081020	SCREW	4
16	1052760	SEAL	2	47	8211220	SCREW	4
17	1052840	WASHER	2	48	8410040	SCREW	1
18	1052880	COVER - WIRE BOX	1	49	8411080	SCREW	4
19	1052920	INSULATION PLATE	1	50	8413080	SCREW	2
20	1053000	PLATE, SPRING BACK UP	1	51	8413120	SCREW	5
21	1053010	ROD ACTUATOR	1	52	8415600	SCREW	1
22	1053220	GASKET	1	53	8500100	NUT	1
23	1053230	GASKET	1	54	8500130	NUT	1
24	1070040	CONNECTING ROD	1	55	8506160	WASHER	1
25	1071324	LUBRICATING FELT	1	56	8506600	WASHER	4
26	2000040	NAME PLATE	1	57	8507090	WASHER	4
27	2000180	SWITCH	1	58	8507100	WASHER	4
28	3000020	WASHER	1	59	8507150	WASHER	6
29	3001020	NUT	1	60	8611600	PIN	1
30	3304040	BEARING	1	61	8613180	PIN	1

**Figure 3 BOM FOR MODEL "500E"**

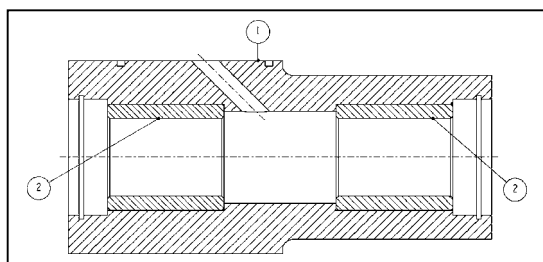

1052140: GUIDE - SAW SHAFT			
ITEM	PART #	DESCRIPTION	QTY
1	1052140-M	GUIDE - SAW SHAFT	1
2	3819120	BUSHING	2

**Figure 4 1052140: GUIDE – SAW SHAFT**

**MOTOR ASSEMBLY**

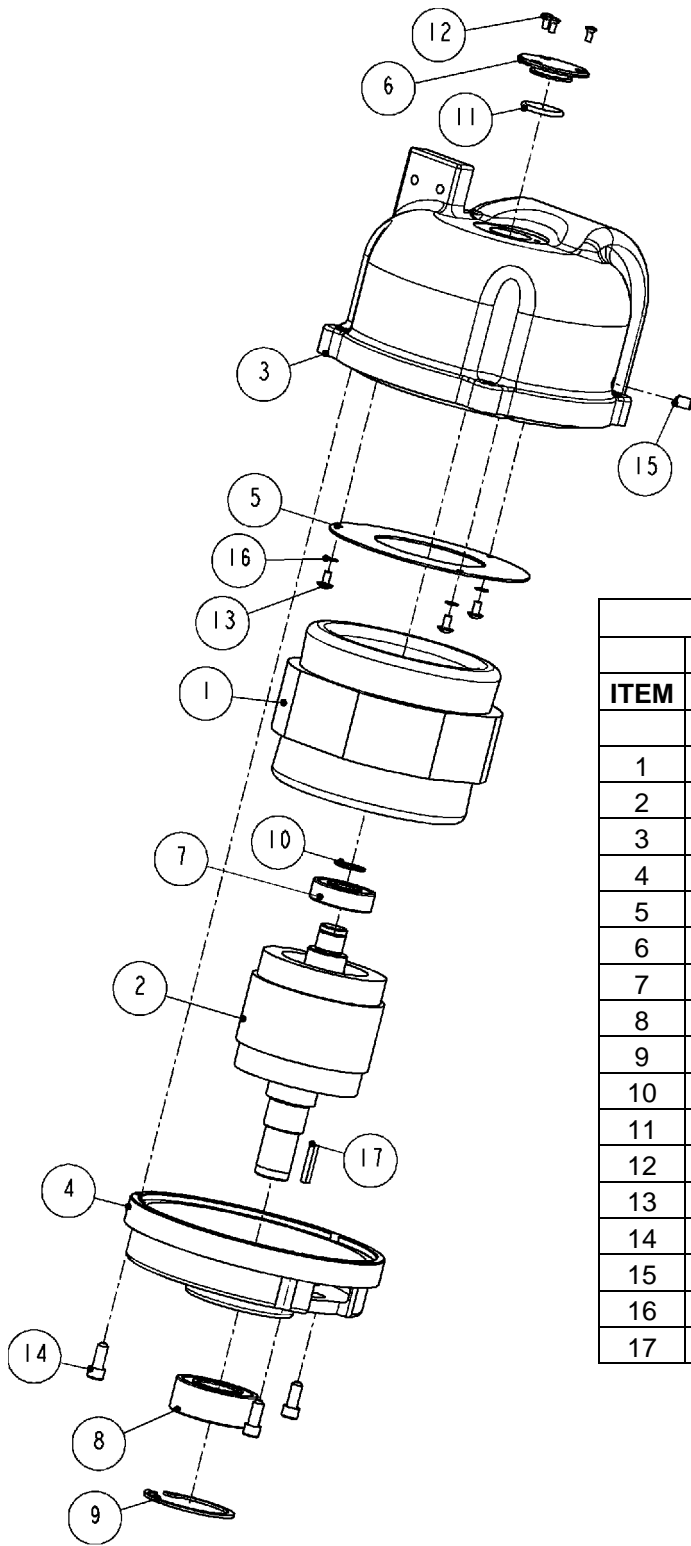

MOTOR ASSEMBLY			
ITEM	PART #	DESCRIPTION	QTY
1	<b>OPTIONS</b>	STATOR	1
2	1051110	ROTOR ASSEMBLY	1
3	1051120	MOTOR SHELL	1
4	1052050	MOTOR BEARING HOUSING	1
5	1052110	PLATE	1
6	1052830	COVER	1
7	3204040	BEARING	1
8	3522060	BEARING	1
9	5002440	RETAINING RING	1
10	5100780	RETAINING RING	1
11	7682140	O-RING	1
12	8048030	SCREW	3
13	8110030	SCREW	3
14	8213060	SCREW	3
15	8313040	SET SCREW	1
16	8507090	WASHER	3
17	8603090	SQUARE KEY	1

**Figure 5 MOTOR ASSEMBLY**

MOTOR ASS'Y 1HP, 550 V, 3 PHASE, 60Hz,	1051250-550-360	2340550	1051110
MOTOR ASS'Y 1HP, 380 V, 3 PHASE, 60Hz, 2.5 AMPS	1051240-380-360	2340540	1051110
MOTOR ASS'Y 1HP, 460 V, 3 PHASE, 60Hz, 2.5 AMPS	1051230-460-360	2340530	1051110
MOTOR ASS'Y 1HP, 230 V, 3 PHASE, 60Hz, 5.0 AMPS	1051230-230-360	2340530	1051110
MOTOR ASS'Y 1HP, 380 V, 3 PHASE, 50Hz, 2.5 AMPS	1051220-380-350	2340520	1051110
MOTOR ASS'Y 1HP, 230 V, 3 PHASE, 50Hz, 5.3 AMPS	1051210-230-350	2340510	1051110
MOTOR ASS'Y 1HP, 115 V, 3 PHASE, 50Hz, 10.6 AMPS	1051210-115-350	2340510	1051110
MOTOR ASS'Y 1HP, 42 V, 3 PHASE, 50Hz, 25 AMPS	1051200	2340500	1051110
<b>DESCRIPTION</b>	<b>MOTOR ASS'Y</b>	<b>STATOR</b>	<b>ROTOR</b>
<b>500E: 1HP MOTOR ASSEMBLY OPTIONS</b>			

**Figure 6 MOTOR ASSEMBLY OPTIONS**

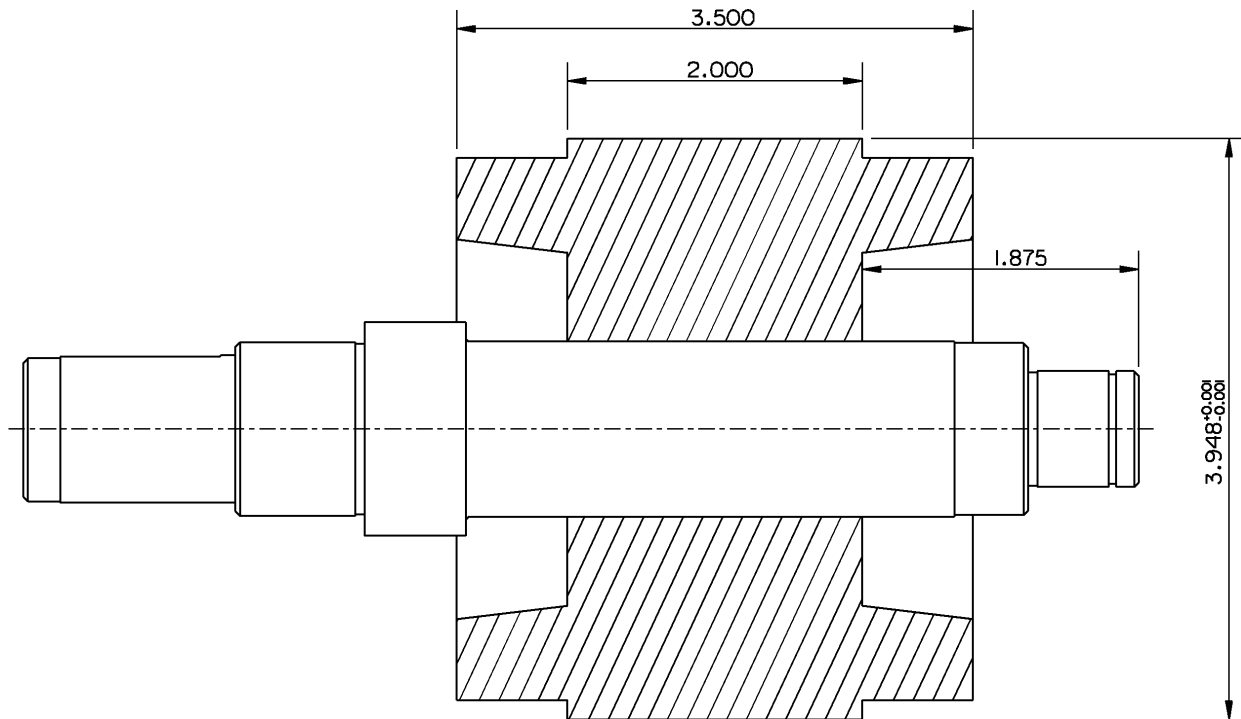

<b>1051110: ROTOR SHAFT ASSEMBLY – 3 PHASE</b>			
ITEM	PART #	DESCRIPTION	QTY
1	1051100	SHAFT - MOTOR	1
2	2340660	ROTOR – 3 PHASE	1

**Figure 7 1051110: ROTOR –SHAFT ASSEMBLY**



**POWER SUPPLY**

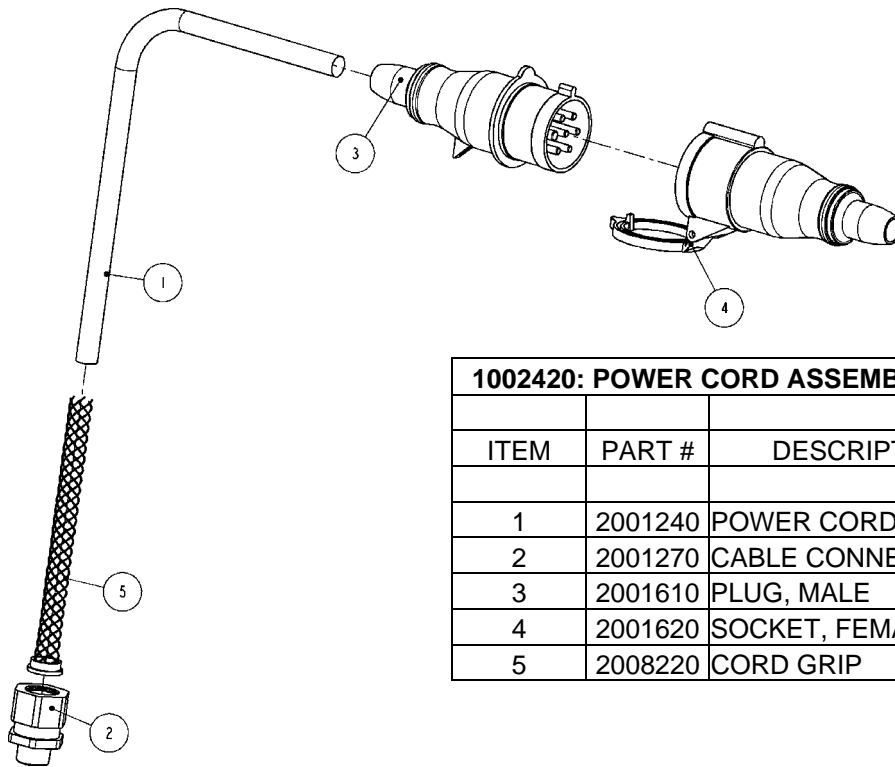

<b>1002420: POWER CORD ASSEMBLY, NON 42V</b>			
ITEM	PART #	DESCRIPTION	QTY
1	2001240	POWER CORD	1
2	2001270	CABLE CONNECTOR	1
3	2001610	PLUG, MALE	1
4	2001620	SOCKET, FEMALE	1
5	2008220	CORD GRIP	1

**Figure 8 1002420: POWER SUPPLY, NON 42V, 3 PHASE**

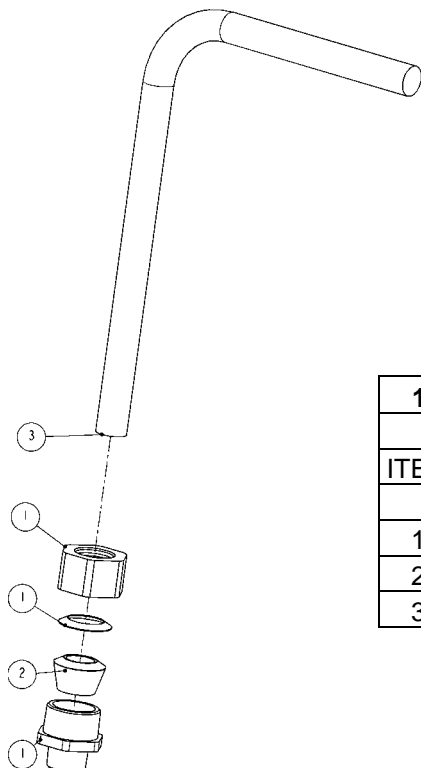

<b>1002430: POWER CORD ASSEMBLY, 42V</b>			
ITEM	PART #	DESCRIPTION	QTY
1	2001270	CABLE CONNECTOR	1
2	2001700	GROMMET	1
3	2007030	POWER CORD	1

**Figure 9 1002430: POWER SUPPLY, 42V, 3 PHASE**

**WIRING DIAGRAMS**

**3-PHASE, DIFFERENT CONTROL AND MOTOR VOLTAGE**

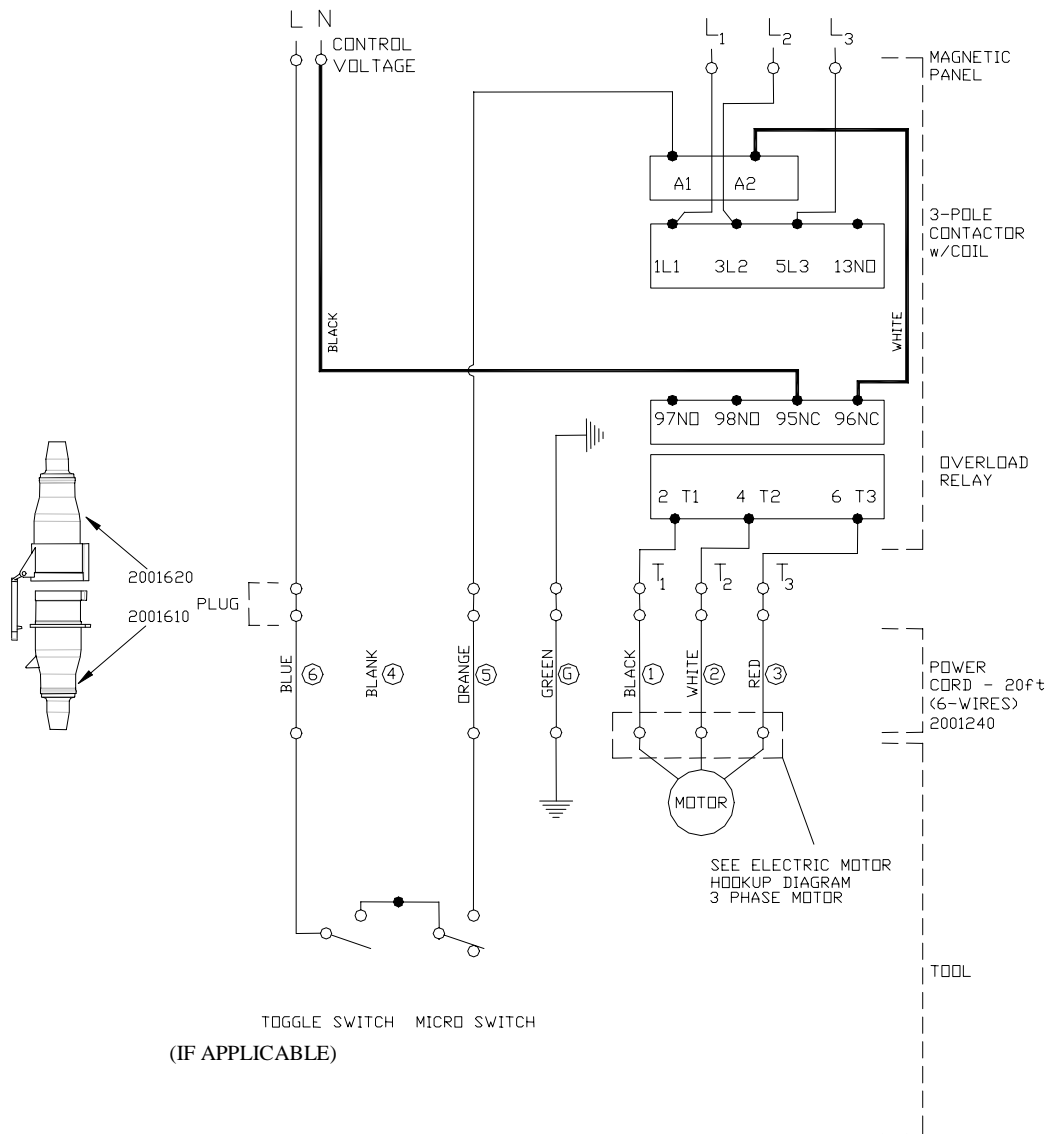

**NOTES:**

1. DO NOT ATTEMPT OR MAKE REPAIRS ON THE MACHINE WHILE POWER IS ON.
2. ALL ELECTRICAL WORK MUST BE PERFORMED BY A QUALIFIED ELECTRICIAN.
3. THE ELECTRICAL DIAGRAM SHOWS THE MACHINE IN THE "OFF" POSITION.
4. THE GROUND WIRE (GREEN) OF THE POWER CABLE IS CONNECTED TO THE FRAME OF THE MACHINE.

**To obtain the correct Kentmaster part number for 3-pole contactor and overload relay, please contact the Kentmaster representative.**

**Figure 10 WIRING DIAGRAM – different control and motor voltage**

**3-PHASE, SAME CONTROL AND MOTOR VOLTAGE**

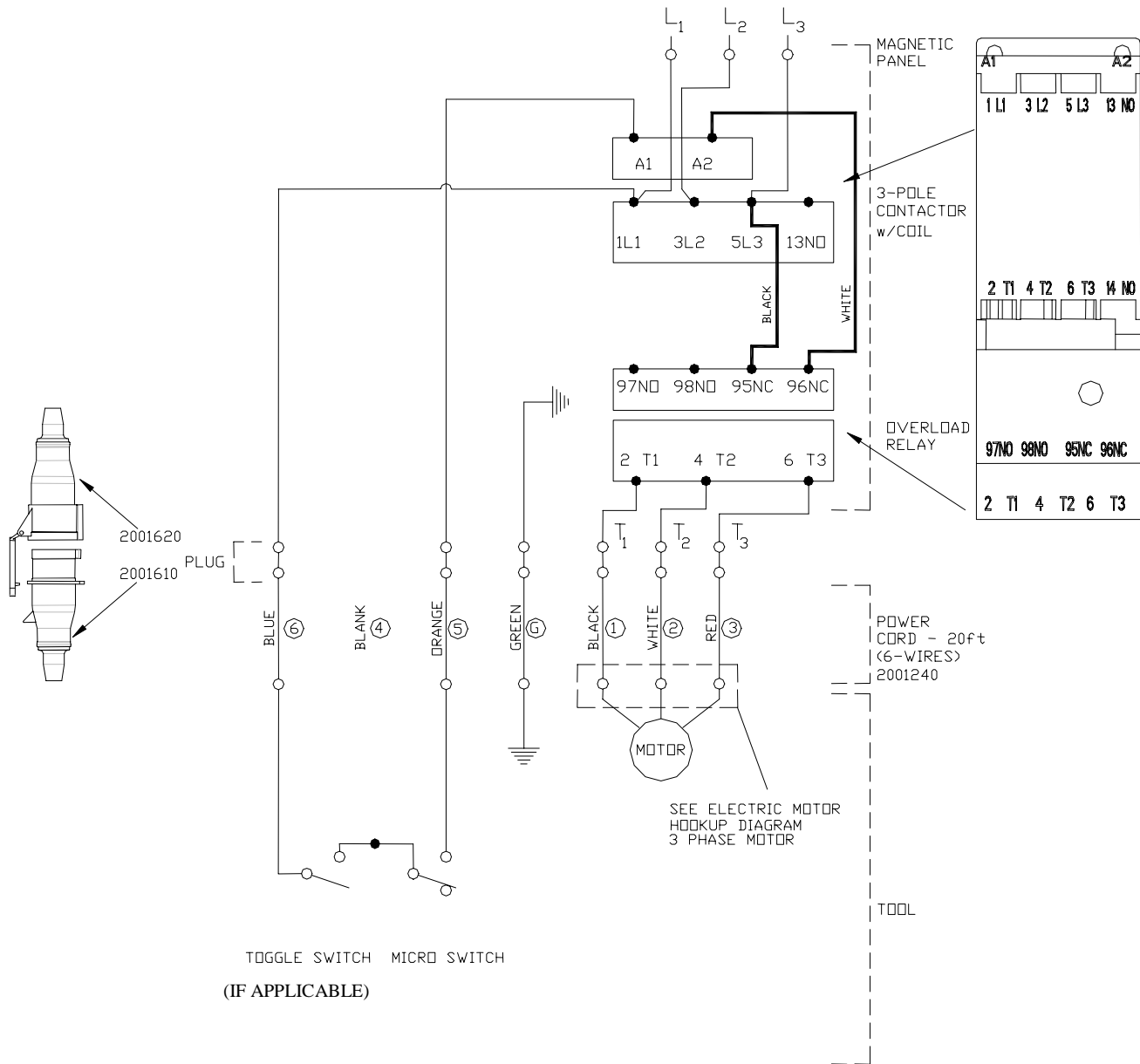

**NOTES:**

1. DO NOT ATTEMPT OR MAKE REPAIRS ON THE MACHINE WHILE POWER IS ON.
2. ALL ELECTRICAL WORK MUST BE PERFORMED BY A QUALIFIED ELECTRICIAN.
3. THE ELECTRICAL DIAGRAM SHOWS THE MACHINE IN THE "OFF" POSITION.
4. THE GROUND WIRE (GREEN) OF THE POWER CABLE IS CONNECTED TO THE FRAME OF THE MACHINE.

**To obtain the correct Kentmaster part number for 3-pole contactor and overload relay, please contact the Kentmaster representative.**

**Figure 11 WIRING DIAGRAM – same control and motor voltage**

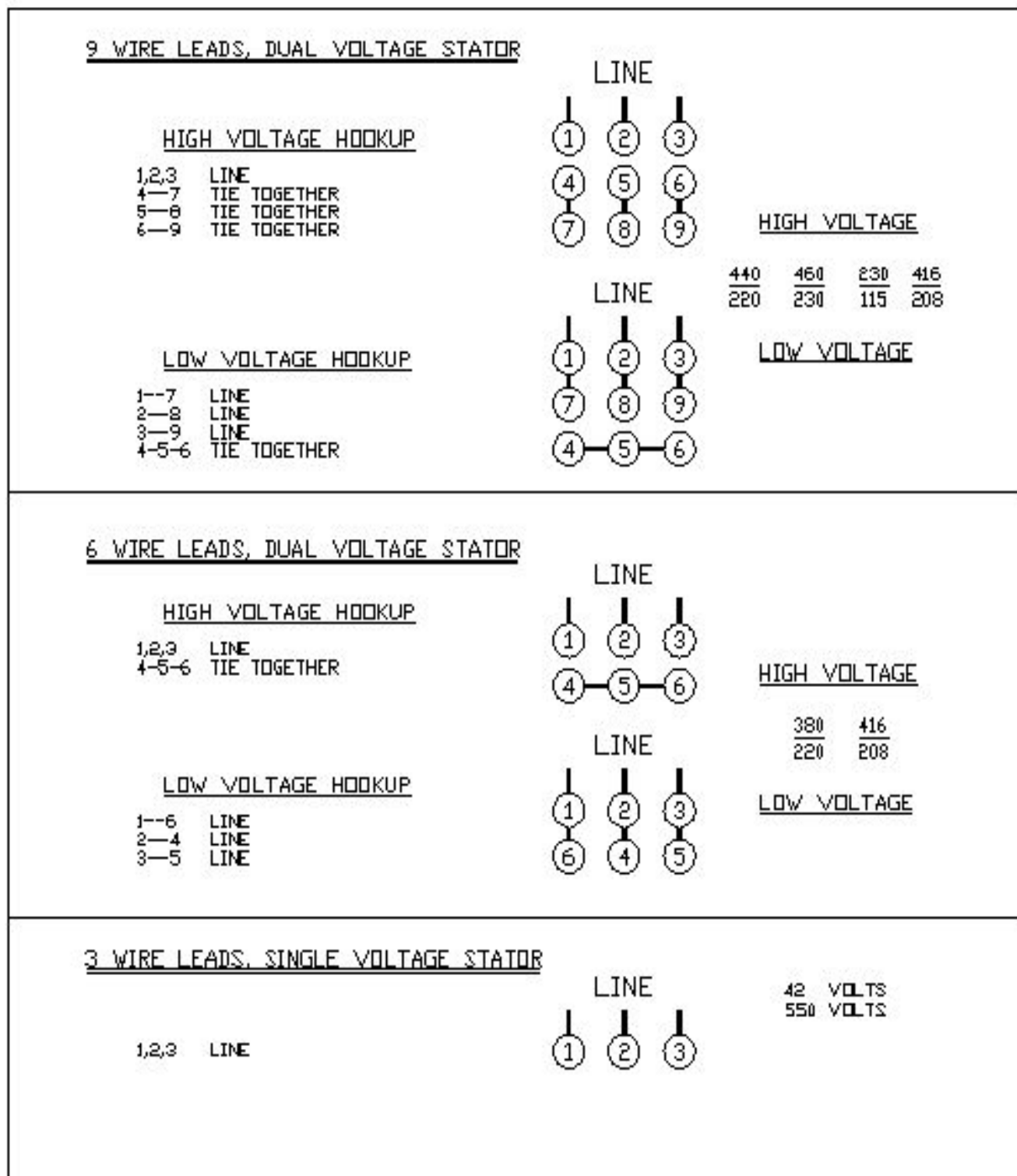

**Figure 12 ELECTRIC MOTOR LEAD HOOKUP DIAGRAM 3 PHASE MOTOR**

[ENGLISH]

## GENERAL INFORMATION

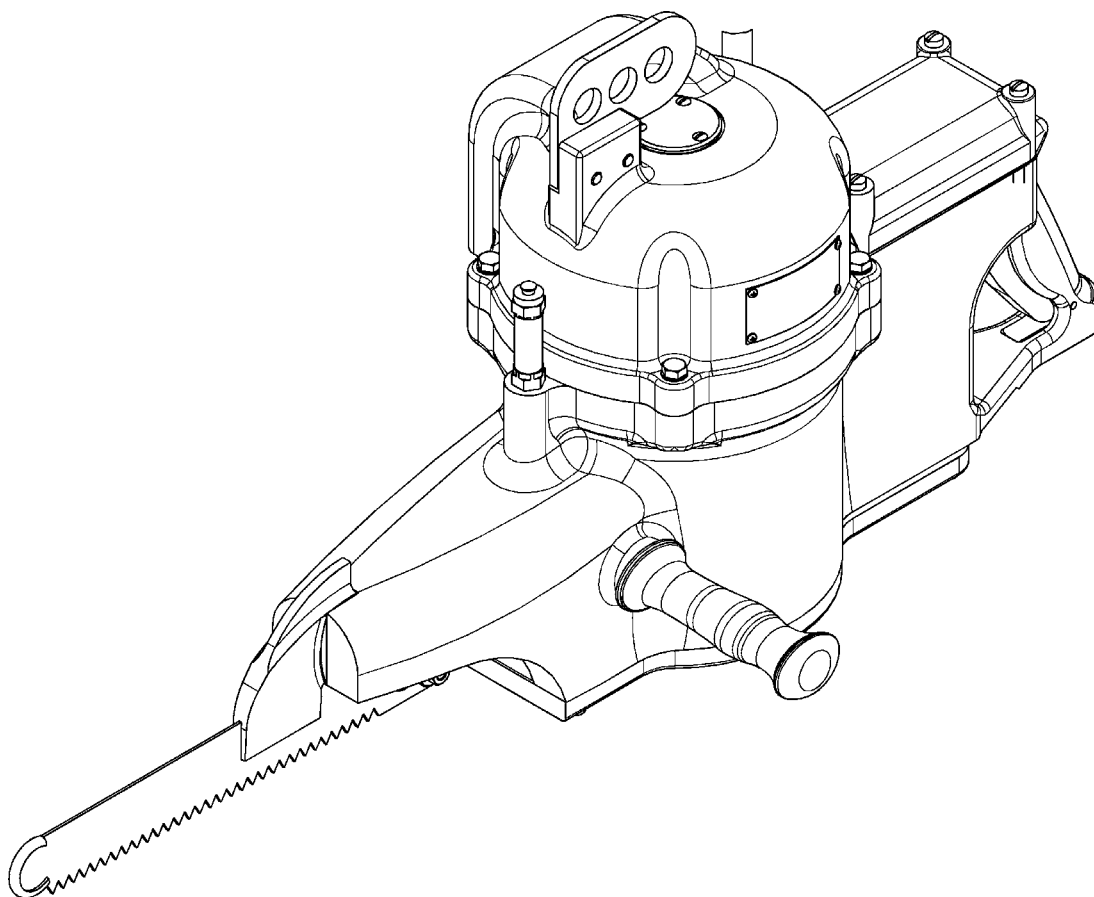

### MODEL

**“500E” BEEF BRISKET SAW (1050000)**

### SERVICE CENTERS

**KENTMASTER LTD. (U.K)**  
16 AVONBANK INDUSTRIAL CENTRE  
WEST TOWN ROAD  
AVONMOUTH - BRISTOL BS11 9DE  
UNITED KINGDOM

☎ **TELEPHONE: ++ 44- (0) 117- 9235035**  
**FAX: ++ 44- (0) 117- 9829010**

**KENTMASTER MFG. CO., INC.**  
1801 SOUTH MOUNTAIN AVE.  
MONROVIA, CALIFORNIA 91016  
UNITED STATES OF AMERICA

☎ **TELEPHONE: (626) 359-8888**  
**FAX: (626) 303-5151**

**NOTICE TO EMPLOYER AND PURCHASER OF TOOL**  
**NOTICE TO SAFETY DIRECTOR**

**You have purchased a powerful tool that, if misused, can cause severe injury and harm to your employees. You must instruct your employees in the safe and proper use of this tool and to follow the safety procedures and instructions that have been supplied by the manufacturer of this tool. Please follow the following instructions.**

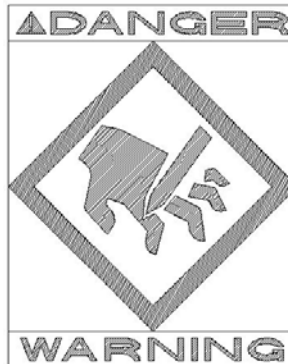

1. Instruct tool operators to test the tool each day before using it to be sure it does not malfunction. Remove and repair any tool that malfunctions.
2. Instruct tool operators to immediately stop using a tool that malfunctions or is defective.
3. Instruct personnel to immediately remove all tools that malfunction. Be sure to disconnect tool from power supply.
4. Instruct all personnel to stay clear of tool, and not to stand or walk in front of, or next to tool when in use.
5. Point out to all personnel the dangers related to the misuse of tool and the importance of following safety procedures and instructions.
6. Do not make, or allow others to make, alterations or modifications to this tool. Replace all lost or illegible labels.
7. Follow all safety, installation and maintenance instructions provided with this tool. Establish proper safety procedures in accordance with local and national requirements to prevent accidental energizing of tool that can cause injuries.
8. If this tool is sold or change in ownership takes place, you must provide the new owner all safety instructions, notices and maintenance instructions you were originally provided. You can obtain additional copies of the instructions from Kentmaster, free of charge upon request.
9. Give copies of instructions to:
  - (A) Tool Operators**
  - (B) Maintenance Supervisor**
  - (C) Clean-up Supervisor**



## GENERAL INFORMATION



COVERING: SAFETY PRECAUTIONS AND PLACING INTO SERVICE  
**ELECTRICAL POWERED BEEF SPLITTING SAW**

**READ THIS MANUAL CAREFULLY BEFORE INSTALLING, OPERATING OR SERVICING  
 THIS TOOL**

IT IS THE RESPONSIBILITY OF THE EMPLOYER TO PLACE THIS INFORMATION INTO THE HANDS OF THE OPERATOR.

### PLACING INTO SERVICE

- |  |   |
|--|---|
|  <b>WARNING</b> | = Hazards or unsafe practices which could result in severe personal injury, death or substantial property damage. |
|  <b>CAUTION</b> | = Hazards or unsafe practices which could result in minor personal injury, product or property damage.            |
|  <b>NOTICE</b>  | = Important installation, operation or maintenance information.   |

- |  |   |
|--|---|
|  <b>WARNING</b> | Installation, adjustment repair and maintenance of this tool must be made by trained and qualified personnel.   |
|  <b>WARNING</b> | Always disconnect power supply from tool before: <ul style="list-style-type: none"> <li>(A) Installing or removing blade from tool.</li> <li>(B) Making repairs or adjustments to the tool.</li> <li>(C) performing maintenance or cleanup work.</li> </ul> |

# DECLARATION OF CONFORMITY

## DECLARATION OF CONFORMITY

DECLARATION DE CONFORMITE -DECLARACION DE CONFORMIDAD- ERKLARUNG BEZUGLICH EINHALTUNG DER VORSCHRIFTEN  
DICHIARAZIONE DI CONFORMITA . CONFORMITEITSVERKLARING

**MANUFACTURED BY:**

FABRIQUE PAR:  
FABRICADA POR:  
HERGESTELLTVON:  
FABBRICATO DA:  
VERVAARDIGD DOOR:

**KENTMASTER MFG CO., INC.**  
**1801 SOUTH MOUNTAIN AVE.**  
**MONROVIA, CALIFORNIA 91016**  
**UNITED STATES OF AMERICA**  
**TELEPHONE (626) 359-8888 FAX (626) 303-5151**

**TYPE / SERIES: BEEF BRISKET SAW**

TYPE / SERIE:  
TIPO / SERIE:  
TYP / SERIE:  
TIPO / SERIE:  
TYPE / SERIE:

**MODEL: 500E**

MODELE:  
MODELO:  
MODELL:  
MODELLO:  
MODEL:

**SERIAL NO. RANGE: XXXXX**

N SERIE: • GAMA DE No. DE SERIE: • SERIEN-NR.-BEREICH: • NUMERI DI SERIE: • SERIENUMMERS:

**This product complies with the following European Community Directives:**

Ce produit est conforme aux directives de la Communaute europeenne suivantes:  
Este producto cumple con las siguientes Directrices de la Comunidad Europea:  
Dieses Produkt erfult die folgenden Vorschriften der Europaischen Gemeinschaft:  
Questo prodotto e conforme alle seguenti direttive CEE:  
Dit produkt voldoet aan de volgende EG-richtlijnen:

**89/392/EEC, 91/368/EEC, 93/44/EEC, 93/68/EEC**

**The following Standards were used to verify compliance with the Directives:**

Les normes suivantes ont ete utilisees pour verifier la conformite avec les Directives:  
Las siguientes Normas se usaron para verificar el cumplimiento de las Directrices:  
Folgende Normen wurden angewandt, um erfaltung der vorschriften zu bestatigen:  
Per verificare la conformita del prodotto alle direttive sono stati usati i seguenti standard:  
De volgende normen zijn gebruikt om naleving van de richtlijnen te bevestigen:

**EN 292**

**Approved by:** \_\_\_\_\_

**Date:** AUG - 1 - 1995

RALPH KARUBIAN MONROVIA, CA. U.S.A  
(Engineering Manager) (Directeur technique) (gerente de ingenieria) (verantwortlicher Konstruktionsleiter) (Responsabile tecnico) (ondersteunend technisch mangar)



## Kentmaster Worldwide Location

Kentmaster Equipment (Aust) PTY.LTD.

Unit 2,24 Central Court  
Browns Plains Qld. 4118  
Australia

Telephone: (07) 3806-8400

Fax: (07) 3806-7933

[Australia@Kentmaster.com](mailto:Australia@Kentmaster.com)

---

Kentmaster do Brasil, Ltda.

Av. Dr. Joao Teodoro No. 805  
Bairro De Vila Rezende  
13405-240 Piracicaba, SP,  
Brazil

Telephone #1: (019) 3 413 3113

Telephone #2: (019)983-4973

Fax: (019) 3 413 3113

[Brazil@Kentmaster.com](mailto:Brazil@Kentmaster.com)

---

Kentmaster (IRL) LTD.

Benamore, Dublin Road.  
Roscrea,  
CO, Tipperary,  
Ireland

Telephone: (353) 0505-23292

Fax: (353) 0505-23299

[Ireland@Kentmaster.com](mailto:Ireland@Kentmaster.com)

---

Kentmaster Equipment (NZ) LTD.

5 Cooper Street  
Havelock North  
New Zealand

Telephone #1: (64) 6 8777 857

Telephone #2: 0800 KENTMASTER

Fax: (64) 6 8777 858

[NewZealand@Kentmaster.com](mailto:NewZealand@Kentmaster.com)

---

Kentmaster South Africa (PTY) LTD.

Johannesburg - S. Africa  
Unit 54 Sunnyrock Park  
Sunrock Close, Germiston  
South Africa

Telephone: (27) 11-455-3748

Fax: (27) 11-455-3749

[SouthAfrica@Kentmaster.com](mailto:SouthAfrica@Kentmaster.com)

---

Kentmaster (UK ) LTD.

Unit 16 Avonbank Ind. Centre  
West Town Rd, Avonmouth-Bristol,  
BS11 9DE  
England

Telephone: (44) 117-923-5035

Fax: (44)-117-932-9010

[UK@Kentmaster.com](mailto:UK@Kentmaster.com)

---

Kentmaster Mfg. Co., Inc.

1801 South Mountain Ave.  
Monrovia, CA, 91016  
USA

Telephone #1: (626) 359-8888

Telephone #2: (800) 421-1477

Fax: (626) 303-5151

[info@Kentmaster.com](mailto:info@Kentmaster.com)

---

Kentmaster Omaha

4417 South 139th Street  
Omaha, NE, 68137  
USA

Telephone #1: (402) 896-3355

Telephone #2: (800) 367-3181

Fax: (402) 896-3311

[Omaha@Kentmaster.com](mailto:Omaha@Kentmaster.com)

---

**INDEX**

**OPERATING AND SAFETY INSTRUCTIONS**..... 2

**OPERATING INSTRUCTIONS**..... 3

**BLADE REMOVAL AND CLEANING**..... 3

**SERVICE**..... 3

**INSTALLATION INSTRUCTIONS** ..... 4

**MAINTENANCE**..... 4

**PARTS BOOK**..... 5

**“500E” MAIN ASSEMBLY**..... 5

**MOTOR ASSEMBLY** ..... 7

**POWER SUPPLY** ..... 9

**WIRING DIAGRAMS** ..... 10

        3-PHASE, DIFFERENT CONTROL AND MOTOR VOLTAGE ..... 10

        3-PHASE, SAME CONTROL AND MOTOR VOLTAGE..... 11

**GENERAL INFORMATION** ..... 15

**DECLARATION OF CONFORMITY**..... 16

**Kentmaster Worldwide Location** ..... 17

**INDEX**..... 18

**FIGURES - INDEX**..... 18

**FIGURES - INDEX**

Figure 1 MODEL 500E – BLADE REPLACEMENT ..... 3

Figure 2 MODEL “500E” ..... 5

Figure 3 BOM FOR MODEL “500E” ..... 6

Figure 4 1052140: GUIDE – SAW SHAFT ..... 6

Figure 5 MOTOR ASSEMBLY ..... 7

Figure 6 MOTOR ASSEMBLY OPTIONS ..... 8

Figure 7 1051110: ROTOR –SHAFT ASSEMBLY ..... 8

Figure 8 1002420: POWER SUPPLY, NON 42V, 3 PHASE..... 9

Figure 9 1002430: POWER SUPPLY, 42V, 3 PHASE ..... 9

Figure 10 WIRING DIAGRAM – different control and motor voltage ..... 10

Figure 11 WIRING DIAGRAM – same control and motor voltage..... 11

Figure 12 ELECTRIC MOTOR LEAD HOOKUP DIAGRAM 3 PHASE MOTOR ..... 12