

SC-400, SC-550, SC-650

SC-400, SC-550, sc-650

INCLUDING: OPERATION, INSTRUCTION, INSTALLATION, MAINTENANCE AND PARTSBOOK

**IMPORTANT: READ THIS MANUAL CAREFULLY BEFORE INSTALLING, OPERATING OR
SERVICING THIS TOOL.**

ALL PURPOSE BREAKING SAW



TOOL DATA

MODEL: SC-400
ASSEMBY NO. 6200000
TYPE: AIR OPERATED
NET WEIGHT: -
INLET AIR PRESSURE:
90 P.S.I. (6 BARS)



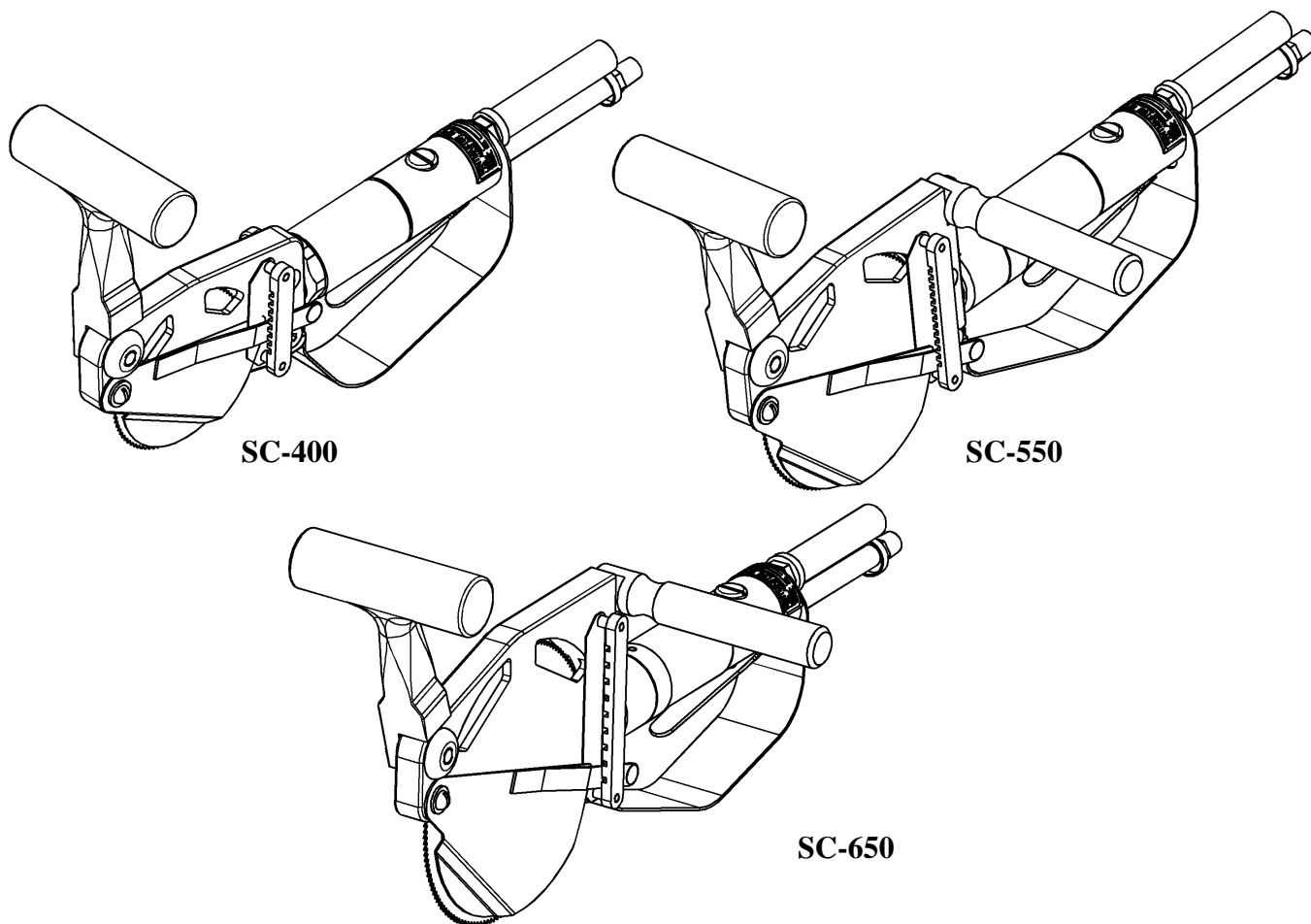











MODEL: SC-500
ASSEMBY NO. 6210000
TYPE: AIR OPERATED
NET WEIGHT: -
INLET AIR PRESSURE:
90 P.S.I. (6 BARS)

MODEL: SC-650
ASSEMBLY NO. 6220000
TYPE: AIR OPERATED
NET WEIGHT: -
INLET AIR PRESSURE:
90 P.S.I. (6 BARS)



 WARNING	= Hazards or unsafe practices which could result in severe personal injury, death or substantial property damage.
 CAUTION	= Hazards or unsafe practices which could result in minor personal injury, product or property damage.
 NOTICE	= Important installation, operation or maintenance information.

OPERATING AND SAFETY INSTRUCTIONS

-  **WARNING** DO NOT OPERATE THIS TOOL UNTIL YOU HAVE READ AND UNDERSTOOD THE SAFETY INSTRUCTIONS AND OPERATING MANUALS.
-  **WARNING** DO NOT OPERATE THIS TOOL UNTIL YOU HAVE RECEIVED TRAINING IN THE HANDLING, OPERATION AND USE OF THIS TOOL.
-  **WARNING** STOP USING A MALFUNCTIONING OR DEFECTIVE TOOL IMMEDIATELY. REPORT ANY PROBLEMS OR DEFECTS TO YOUR SUPERVISOR FOR REMOVAL OF THE TOOL FROM SERVICE.
-  **WARNING** DO NOT ATTEMPT TO REPAIR THE TOOL YOURSELF.
-  **WARNING** DO NOT ALLOW UNAUTHORIZED PERSONS TO USE TOOL.
-  **WARNING** REMOVE AND DISCONNECT POWER FROM THE TOOL WHEN TOOL IS LEFT UNATTENDED OR IS NOT IN USE.
-  **WARNING** NEVER TIE DOWN, BYPASS, ALTER OR MODIFY THE ACTIVATING SWITCHES OR TRIGGERS OF THIS TOOL.
-  **WARNING** NEVER MAKE ALTERATIONS OR MODIFICATIONS TO THIS TOOL.
-  **WARNING** BE CONSTANTLY AWARE AND ALERT FOR UNSAFE CONDITIONS AND REPORT THEM IMMEDIATELY TO YOUR SUPERVISOR.
-  **WARNING** NEVER PLACE YOUR HAND OR ANY PART OF YOUR BODY IN THE CUTTING PATH OF THE TOOL.
-  **WARNING** NEVER ALLOW ANYONE ELSE TO PLACE THEIR HANDS OR ANY PART OF THEIR BODY IN THE CUTTING PATH OF THE TOOL.
-  **WARNING** DO NOT ACTIVATE CONTROL SWITCHES OR TRIGGERS OF THIS TOOL UNLESS YOU INTEND TO TEST OR OPERATE THIS TOOL.
-  **WARNING** DO NOT USE THIS TOOL FOR ANY PURPOSE OTHER THAN IT'S INTENDED PURPOSE.
-  **CAUTION** WHEN OPERATING THIS TOOL WEAR THE PROTECTIVE GEAR AND SAFETY EQUIPMENT SUPPLIED TO YOU.
-  **WARNING** THE NOISE EMISSION (SOUND PRESSURE LEVEL) AT THE WORKSTATION MAY EXCEED 80 dB (A). EAR AND SOUND PROTECTION GEAR IS REQUIRED.

OPERATING INSTRUCTIONS

⚠ WARNING ONLY TRAINED PERSONNEL ARE TO OPERATE THIS TOOL.

1. TO ENSURE TOOL IS OPERATING PROPERLY, PERFORM FOLLOWING STEPS AT START OF EACH SHIFT:
 - MAKE SURE TOOL MOVES UP AND DOWN FREELY WHILE HANGING FROM BALANCER OVERHEAD.
 - WITH POWER TO TOOL TURNED ON, TEST TRIGGER FOR PROPER OPERATION.
 - DEPRESS EACH TRIGGER SEPARATELY. TOOL SHOULD NOT ACTIVATE. DEPRESS BOTH TRIGGERS. TOOL SHOULD ACTIVATE.
 - IF TOOL HAS "ANTI-TIE DOWN" OPTION, BOTH TRIGGERS MUST BE DEPRESSED SIMULTANEOUSLY FOR TOOL TO ACTIVATE.
2. TO PERFORM WORK, HOLD TOOL FIRMLY AT BOTH HANDLES. SQUEEZE TRIGGERS TO ACTIVATE TOOL.
3. DO NOT EXERT EXCESSIVE PRESSURE. ALLOW TIME FOR THE TOOL TO CUT.
4. TOOL REQUIRES 40 S.C.F.M. OF AIR @ 90 P.S.I. AIR PRESSURE.

MAINTENANCE

⚠ WARNING ONLY TRAINED AND QUALIFIED PERSONNEL ARE TO PERFORM MAINTENANCE AND SERVICE TO THIS TOOL.

1. FILL LUBRICATOR WITH KENTMASTER AIR MIST OIL (PART NO. 7903050). SET DRIP RATE ACCORDING TO INSTRUCTIONS SUPPLIED.
2. TOOL REQUIRES GREASING AT START OF EVERY SHIFT. GREASE USING KENTMASTER GREASE (PART NO. 7903070).
3. FLUSH AIR MOTOR AT END OF EACH DAY'S USE BY SQUIRTING A FEW SQUIRTS OF KENTMASTER AIR OIL MIST (PART NO. 7903050) DIRECTLY INTO THE AIR INLET PORT. RUN TOOL A FEW SECONDS TO COAT AND PROTECT THE AIR MOTOR AND INTERNAL PARTS OF TOOL.

BLADE REMOVAL AND CLEANING.

⚠ WARNING ALWAYS DISCONNECT POWER SUPPLY FROM TOOL BEFORE INSTALLING OR REMOVING BLADE FROM TOOL.

⚠ WARNING ALWAYS WEAR WIRE MESH GLOVES WHEN INSTALLING OR REMOVING BLADE FROM TOOL.

1. TO REMOVE BLADE, LOOSEN (2) SCREWS, FIGURE 1, ITEM 1 AND GUARD, ITEM 2.
2. REMOVE SCREW, ITEM 3, BLADE HOLDER, ITEM 4 AND BLADE, ITEM 5.
3. CLEAN ALL PARTS REMOVED WITH SOAP AND WATER.
4. SHARPEN OR REPLACE BLADE WHEN NECESSARY AND LUBRICATE ALL PARTS.
5. REASSEMBLE ALL PARTS IN REVERSE ORDER.

AT END OF EACH SHIFT:

1. REMOVE SAW BLADE.
2. IF USING BLADE AGAIN, WASH BLADE WITH HOT WATER TO REMOVE FAT, MEAT AND BONE PARTICLES.
3. DRY AND APPLY A COAT OF MINERAL OIL TO ENTIRE SURFACE OF BLADE TO AVOID OXIDATION.

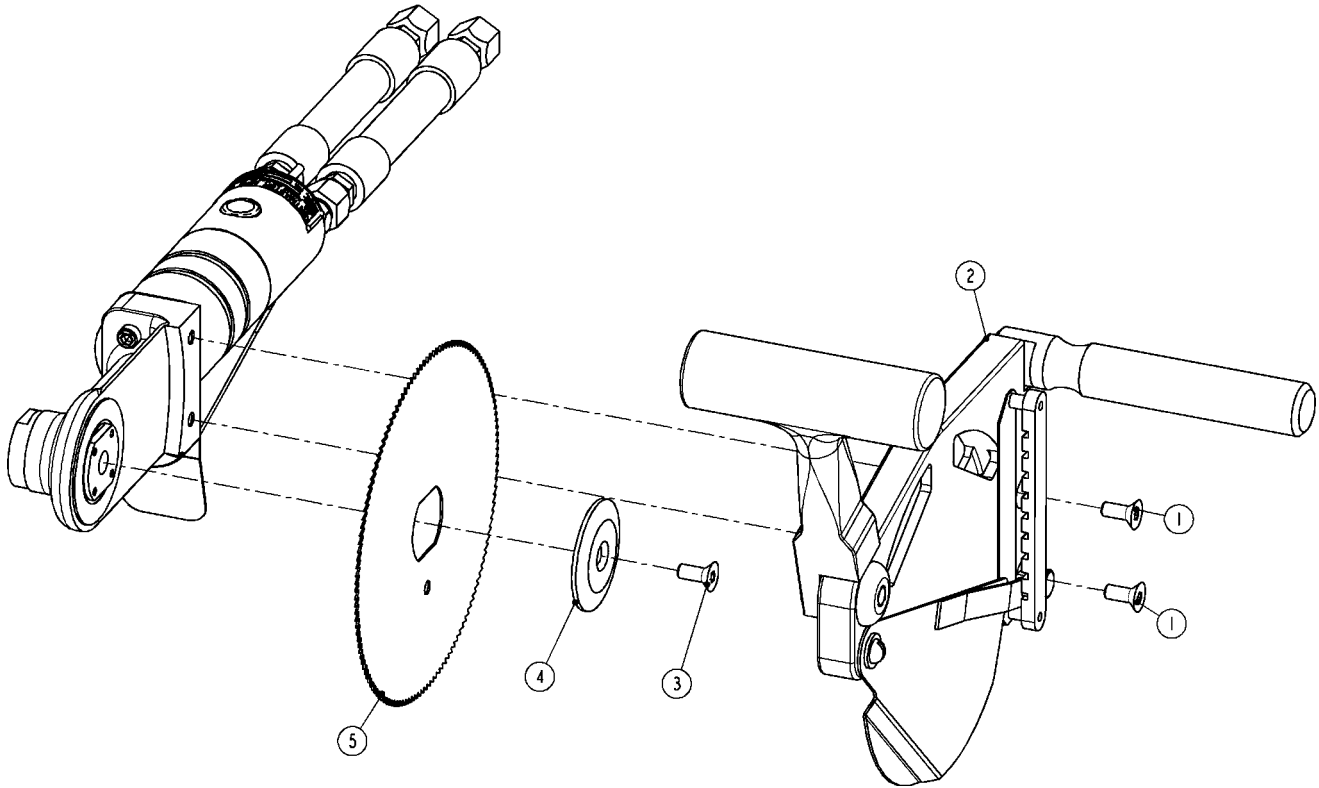

Figure 1 SC-
SERVICE

1. KEEP GOOD RECORDS OF ALL SERVICE ACTIVITY AND INCLUDE TOOL IN PREVENTIVE MAINTENANCE PROGRAM.
2. USE ONLY GENUINE KENTMASTER REPLACEMENT PARTS TO ASSURE PROPER PERFORMANCE OF TOOL.
3. CONTACT THE KENTMASTER SUPPLIER NEAREST YOU FOR PARTS AND CUSTOMER SERVICE INFORMATION.



PARTS BOOK

SC-400, SC-550, SC-650
MODEL SC-400, SCRIBE SAW

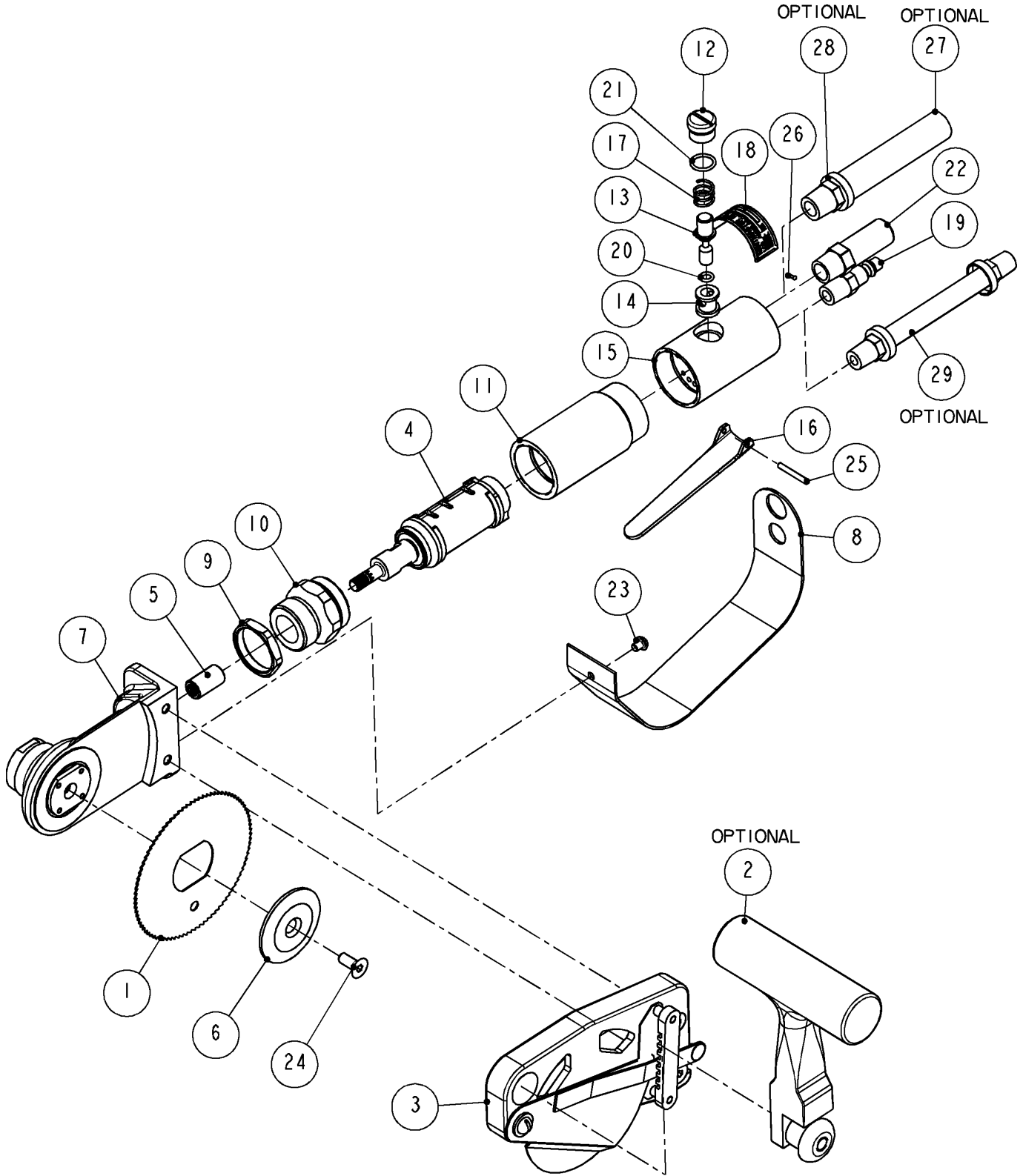

Figure 2 MODEL SC-400

6200000: SC-400, AIR OPERATED SCRIBE SAW			
ITEM	PART #	DESCRIPTION	QTY
1	4000600	4.0" SAW BLADE	1
2	6201640	FRONT HANDLE / OPTIONAL	1
3	6200220	BLADE GUARD & DEPTH GAUGE, 4" BLADE	1
4	6200800	AIR MOTOR	1
5	6201010	COUPLING	1
6	6201120	HOLDER, BLADE	1
7	6201250	GEAR HOUSING ASSEMBLY 4" & 5.5" BLADE	1
8	6201270	GUARD	1
9	6201500	LOCK NUT	1
10	6201510	ADAPTER	1
11	6201520	SHELL, MOTOR	1
12	6201530	PLUG	1
13	6201540	VALVE	1
14	6201550	BUSHING, VALVE	1
15	6201560	BODY, VALVE	1
16	6211670	LEVER	1
17	6211680	SPRING	1
18	6211690	NAME PLATE	1
19	7034070	MALE PLUG	1
20	7680090	O-RING	1
21	7680140	O-RING	1
22	7802220	MUFFLER	1
23	8029020	SCREW	1
24	8241050	SCREW	1
25	8620080	PIN	1
26	8640030	DRIVE SCREW	4
27	7301850	HOSE / OPTIONAL	1
28	7301860	FITTING / OPTIONAL	1
29	7310600	HOSE ASSEMBLY / OPTIONAL	1

Figure 3 BOM FOR MODEL SC-400

SC-400, SC-550, SC-650
MODEL SC-550 & SC-650, SCRIBE SAW

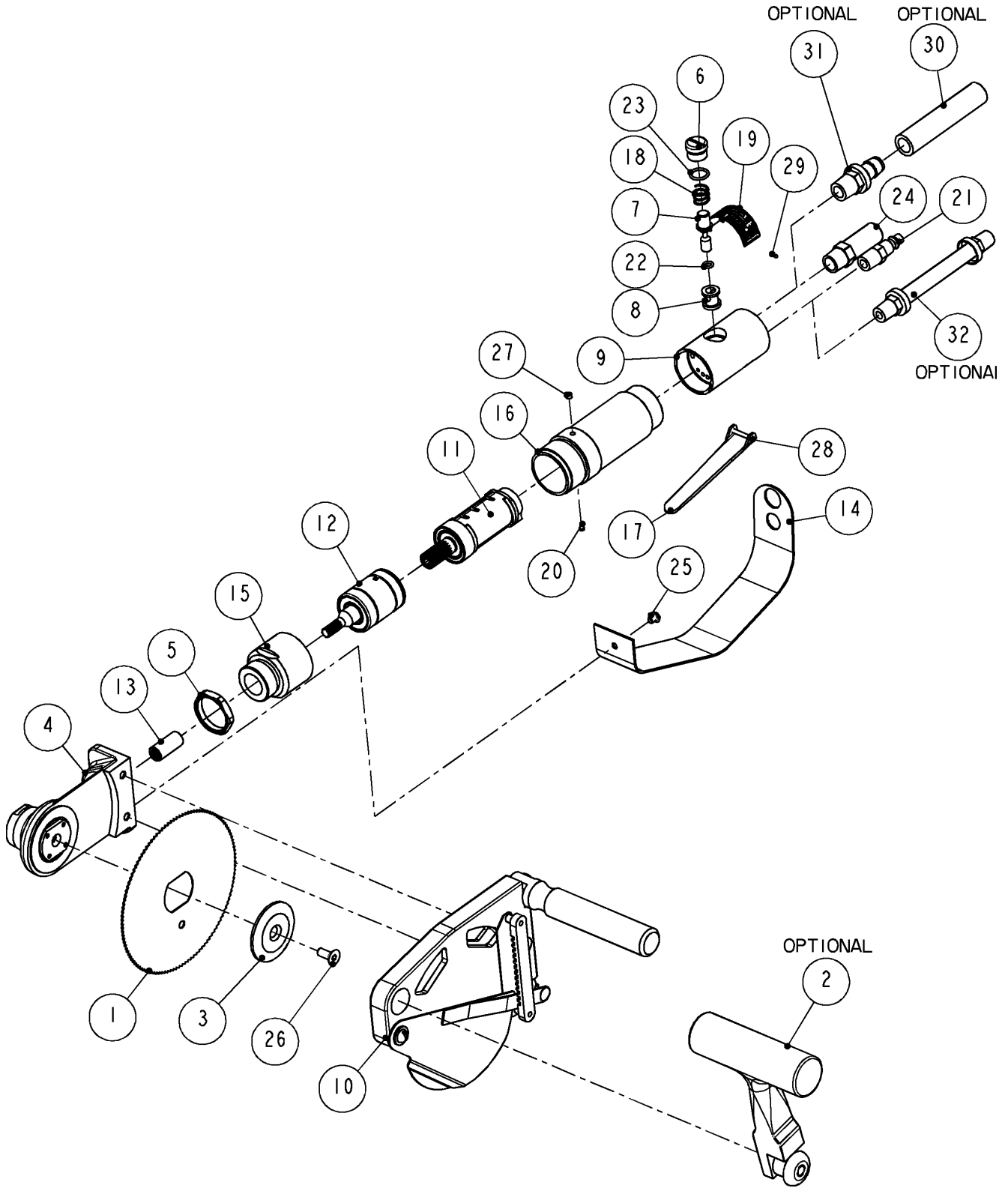

Figure 4 MODEL SC-500 & SC-650

KENTMASTER MFG. CO., INC. 1801 SOUTH MOUNTAIN AVE., MONROVIA, CALIFORNIA 91016 UNITED STATES OF AMERICA
 ① TELEPHONE: (626) 359-8888 FAX: (626) 303-5151

SC-400, SC-550, SC-650

6210000: SC-550 & 622000: SS-650				
			6210000	6220000
			SC-550	SC-650
ITEM	PART #	DESCRIPTION	QTY	QTY
1	4000610	5.5" SAW BLADE, 120 TOOTH	1	-
	4000630	5.5" SAW BLADE, 65 TOOTH	1	-
	4000640	5.5" SAW BLADE, SKIP TOOTH, 65 TOOTH	1	-
	4000050	6.5" SAW BLADE, 140 TOOTH	-	1
	4000620	6.5" SAW BLADE, 70 TOOTH	-	1
	4000650	6.5" SAW BLADE, SKIP TOOTH, 70 TOOTH	-	1
2	6201640	FRONT HANDLE / OPTIONAL	1	1
3	6201120	HOLDER, BLADE	1	1
4	6201250	GEAR HOUSING ASSEMBLY 4" & 5.5" BLADE	1	-
	6221090	GEAR HOUSING ASSEMBLY 6.5" BLADE	-	1
5	6201500	LOCK NUT	1	1
6	6201530	PLUG	1	1
7	6201540	VALVE	1	1
8	6201550	BUSHING, VALVE	1	1
9	6201560	BODY, VALVE	1	1
10	6210220	BLADE GUARD w/DEPTH GAUGE, 5.5" BLADE	1	-
	6220220	BLADE GUARD w/DEPTH GAUGE, 6.5" BLADE	-	1
11	6210800	AIR MOTOR ASSEMBLY	1	1
12	6210810	PLANETARY GEAR ASSEMBLY	1	1
13	6211010	COUPLING	1	-
	6221010	COUPLING	-	1
14	6211120	GUARD	1	1
15	6211500	ADAPTER	1	1
16	6211510	SHELL, MOTOR	1	1
17	6211670	LEVER	1	1
18	6211680	SPRING	1	1
19	6211690	NAME PLATE	1	1
20	7014050	FITTING, LUBRICATION	1	1
21	7034070	MALE PLUG	1	1
22	7680090	O-RING	1	1
23	7680140	O-RING	1	1
24	7802220	MUFFLER	1	1
25	8029020	SCREW	1	1
26	8241050	SCREW	1	1
27	8335000	SET SCREW	1	1
28	8620080	PIN	1	1
29	8640030	DRIVE SCREW	4	4
30	7301850	HOSE / OPTIONAL	1	1
31	7301860	FITTING / OPTIONAL	1	1
32	7310600	HOSE ASSEMBLY / OPTIONAL	1	1

Figure 5 BOM FOR MODELS SC-500 & SC-650

GEARS AND GEAR HOUSING ASSEMBLY

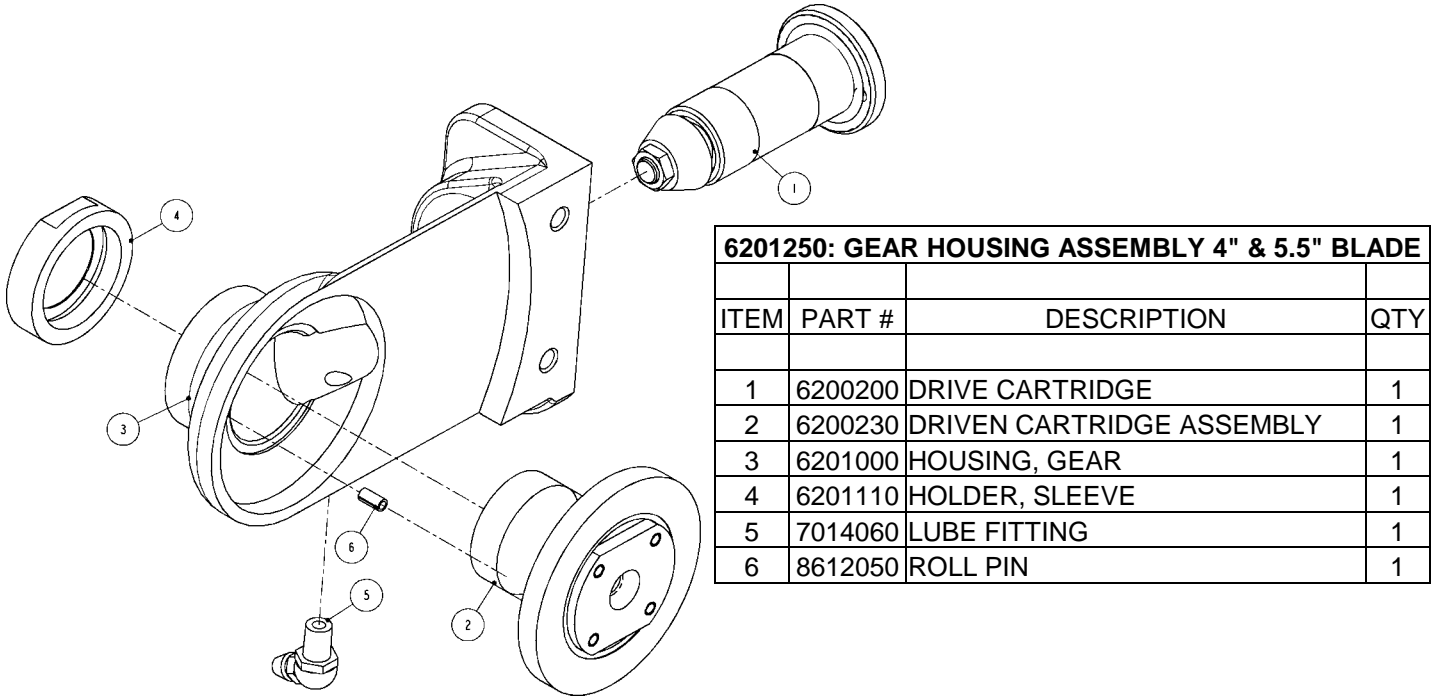

Figure 6 6201250: GEAR HOUSING ASSEMBLY, SC-400 & SC-550

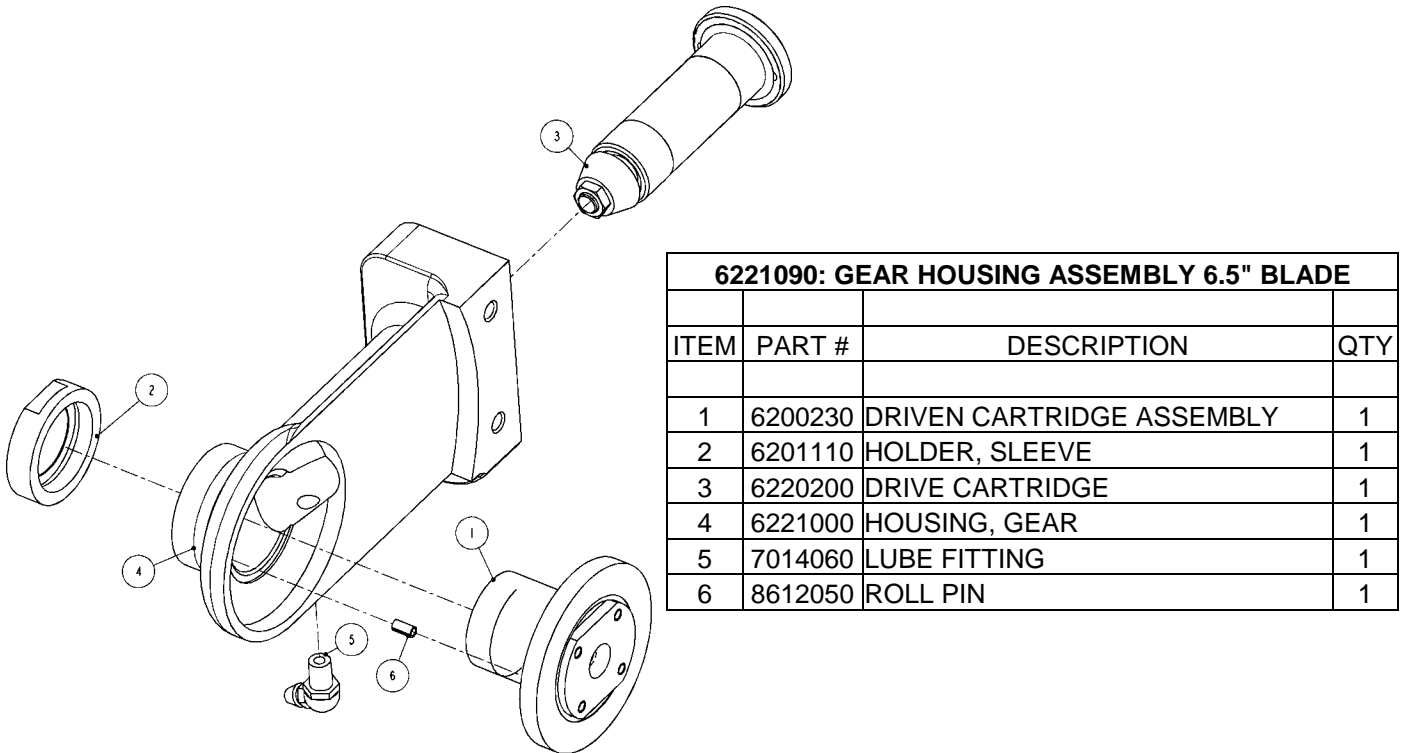

Figure 7 6201250: GEAR HOUSING ASSEMBLY, SC-650

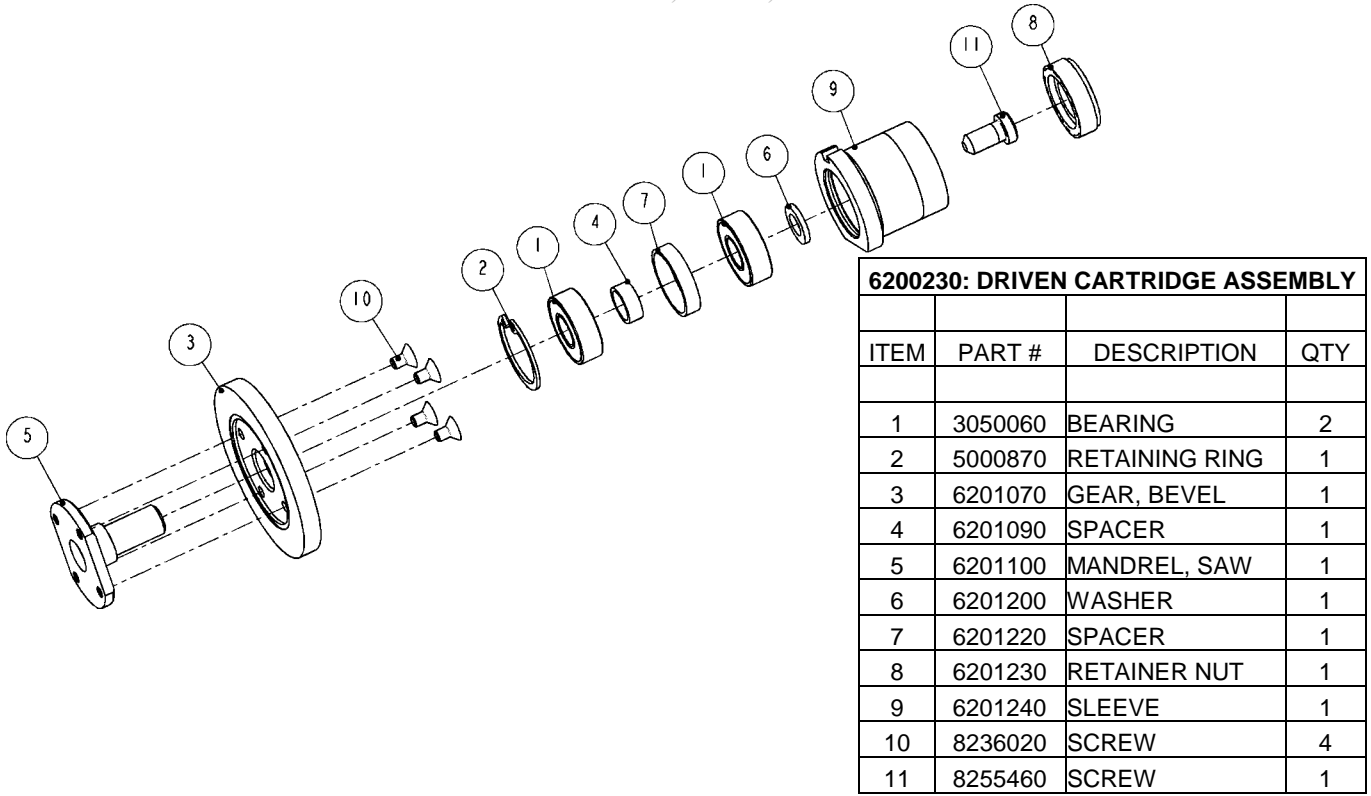

Figure 8 6200230: DRIVEN CARTRIDGE ASSEMBLY

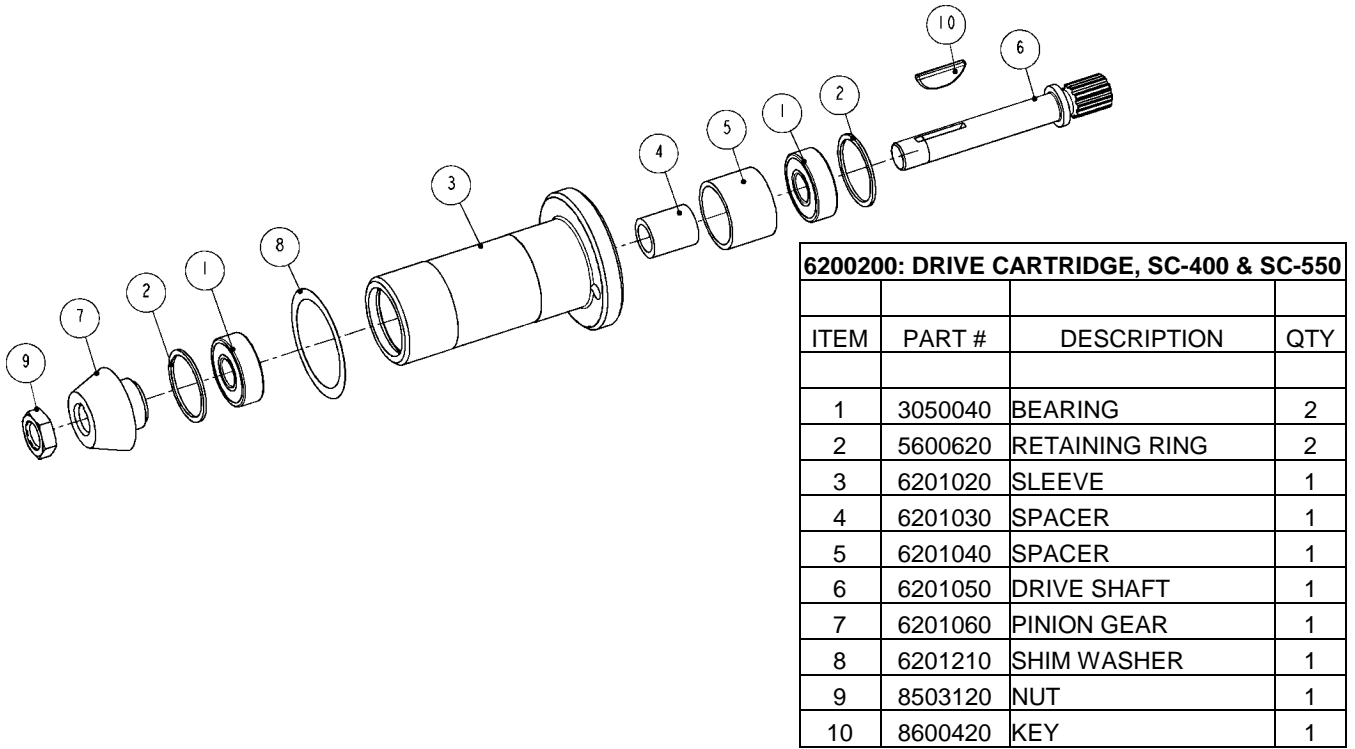
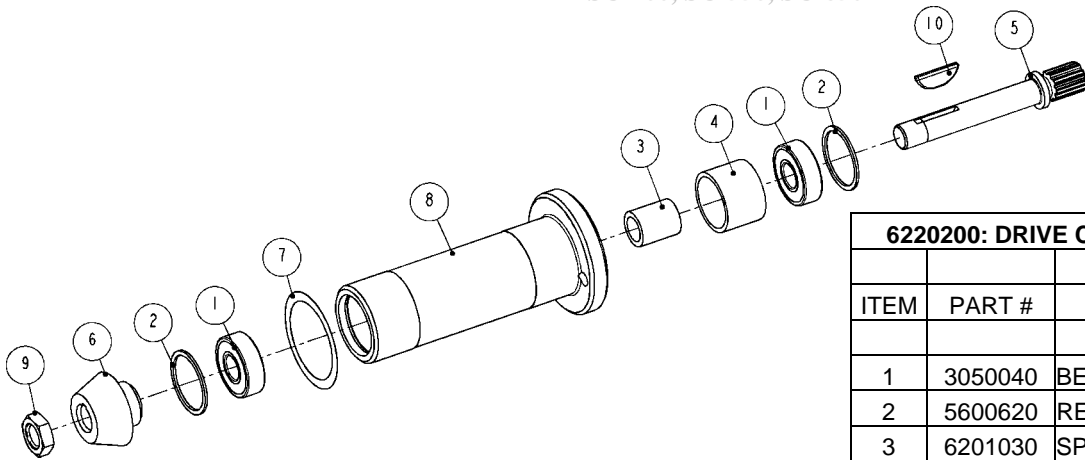

Figure 9 6220200: DRIVE CARTRIDGE ASSEMBLY, SC-400 & SC-550



6220200: DRIVE CARTRIDGE, SC-650			
ITEM	PART #	DESCRIPTION	QTY
1	3050040	BEARING	2
2	5600620	RETAINING RING	2
3	6201030	SPACER	1
4	6201040	SPACER	1
5	6201050	DRIVE SHAFT	1
6	6201060	PINION GEAR	1
7	6201210	SHIM WASHER	1
8	6221020	SLEEVE	1
9	8503120	NUT	1
10	8600420	KEY	1

Figure 10 6220200: DRIVE CARTRIDGE ASSEMBLY, SC-650

SPECIAL TOOLS (OPTIONAL)

4501470	GREASE GUN
4501460	WRENCH, DRIVE SHAFT SLEEVE
4501450	WRENCH, ADAPTER (1-1/2)
4501440	WRENCH, LOCKNUT (1-3/8)
4501430	WRENCH, SLEEVE HOLDER (1-1/4)
ITEM	DESCRIPTION
SPECIAL TOOLS (OPTIONAL)	

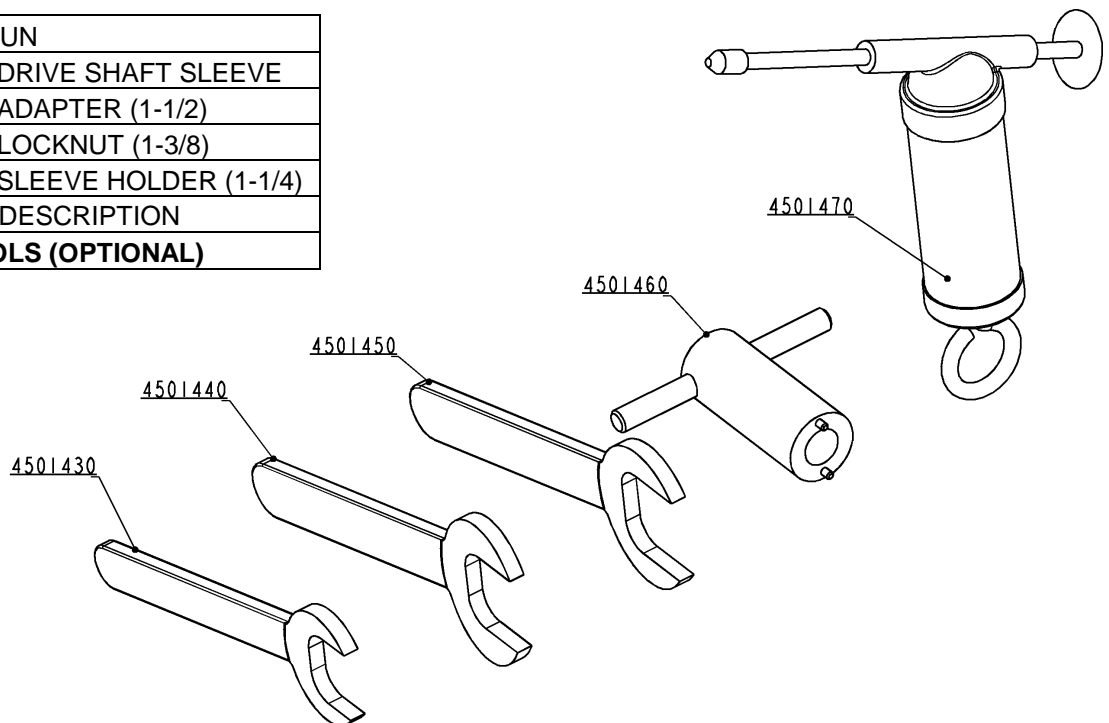
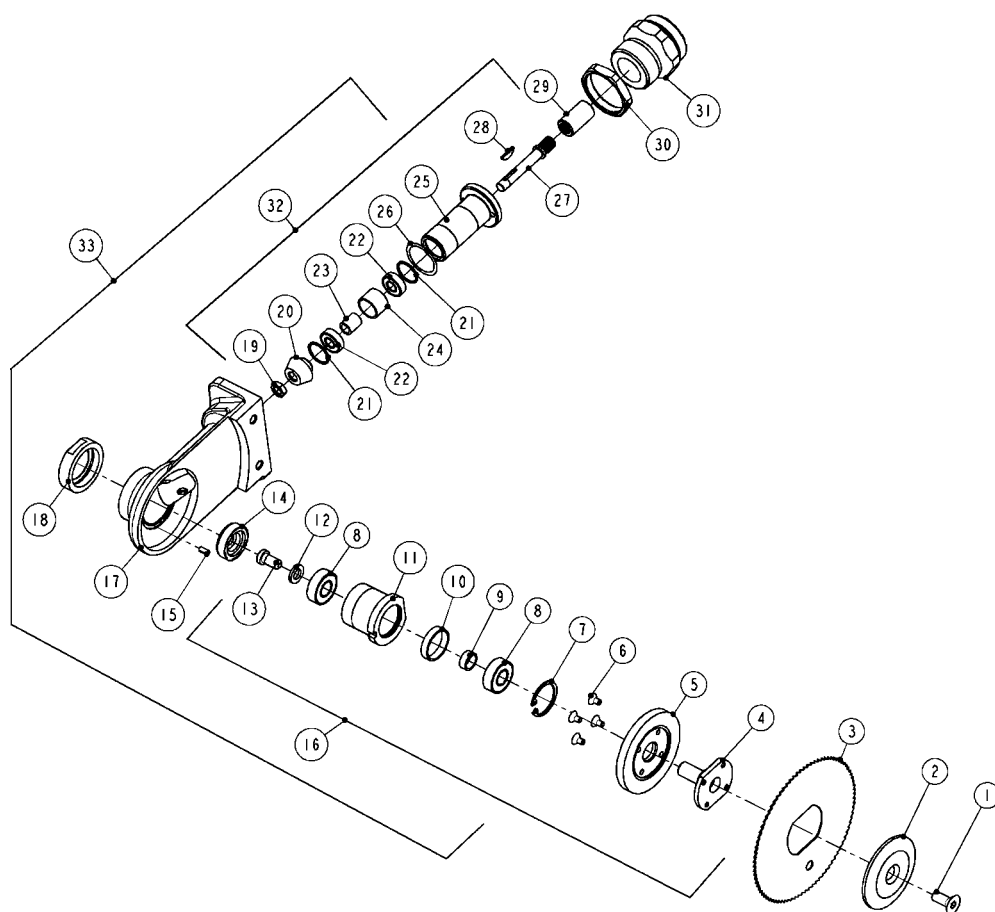

Figure 11 SC-, SPECIAL TOOLS (OPTIONAL)



GEAR HOUSING DISASSEMBLY

⚠ WARNING ALWAYS WEAR WIRE MESH GLOVES WHEN INSTALLING OR REMOVING BLADE FROM TOOL.

1. REMOVE SCREW, HOLDER AND BLADE, ITEMS 1-3.
2. REMOVE HOLDER, ITEM 18. THE CARTRIDGE ASSEMBLY, ITEM 16, SHOULD JUST SLIDE OUT.
3. REMOVE NUT AND SCREW, ITEMS 13 AND 14.
4. PRESS MANDREL, ITEM 4, OUT THRU BEARINGS, ITEM 8.
5. REMOVE (4) SCREWS, ITEM 6, TO DISASSEMBLE GEAR AND MANDREL, ITEMS 4 AND 5.
6. REMOVE RETAINING RING, ITEM 7, PRIOR TO PRESSING OUT BEARINGS, ITEM 8.
7. LOOSEN LOCKNUT, ITEM 30, AND REMOVE ADAPTOR, ITEM 31.
8. USING WRENCH, ITEM 4501460, SCREW OUT CARTRIDGE ASSEMBLY, ITEM 32.
9. REMOVE NUT, ITEM 19. GEAR, ITEM 20, SHOULD JUST COME OFF.
10. PRESS OUT KEY AND SHAFT, ITEMS 27 & 28.
11. REMOVE (2) RETAINING RINGS, ITEM 21, PRIOR TO PRESSING OUT BEARINGS AND SPACERS, ITEMS 22-24.

GEAR HOUSING REASSEMBLY

1. SHARPEN OR REPLACE BLADE AS NECESSARY.
2. CLEAN AND LUBRICATE ALL PARTS.
3. REPLACE PARTS AS NEEDED.
4. REASSEMBLE PARTS IN REVERSE ORDER.

Figure 12 GEAR HOUSING ASSEMBLY PROCESS

SC-400, SC-550, SC-650
AIR MOTOR ASSEMBLY

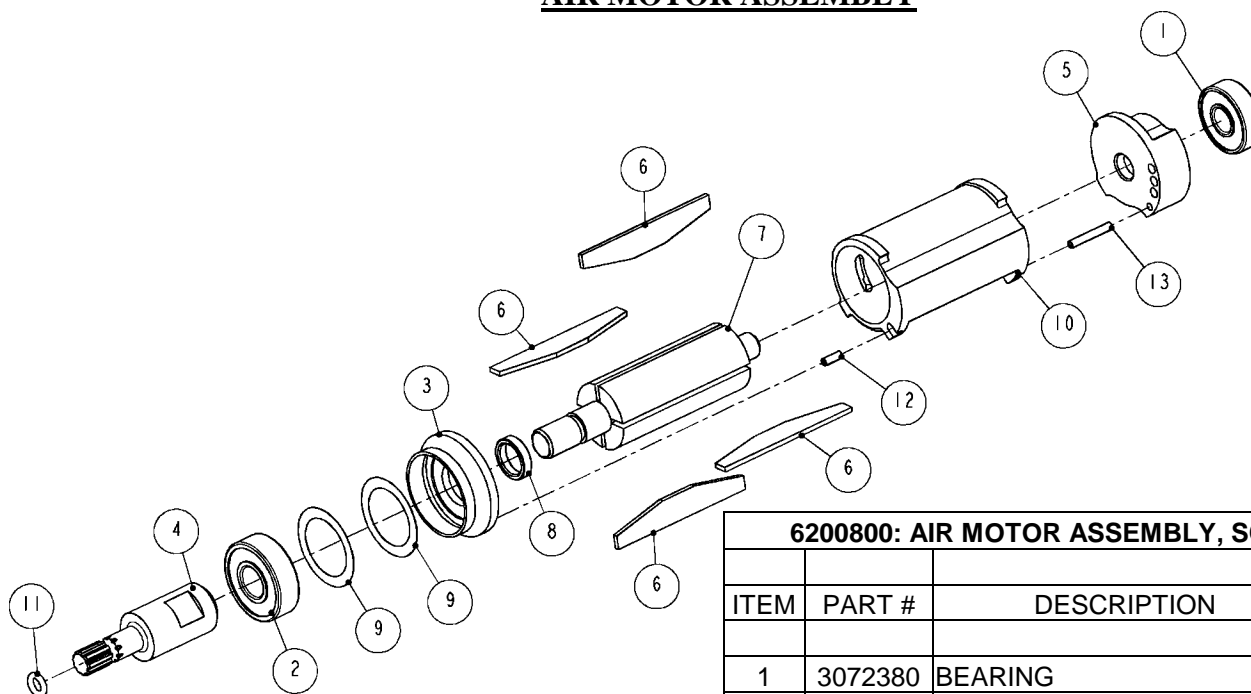

6200800: AIR MOTOR ASSEMBLY, SC-400			
ITEM	PART #	DESCRIPTION	QTY
1	3072380	BEARING	1
2	3122000	BEARING	1
3	6201570	PLATE, BEARING FRONT	1
4	6201580	ADAPTER, SPLINE	1
5	6201590	PLATE, REAR BEARING	1
6	6211520	BLADE, MOTOR	4
7	6211530	ROTOR	1
8	6211540	SPACER, ROTOR	1
9	6211560	SHIM	2
10	6211610	CYLINDER	1
11	7680080	O-RING	1
12	8611540	ROLL PIN	1
13	8611600	ROLL PIN	1

MOTOR DISASSEMBLY

1. TO DISASSEMBLE, PRESS ROTOR, ITEM 7, OUT THRU BEARING, ITEM 1. MOTOR ASSEMBLY SHOULD SLIDE APART.
2. TO SEPARATE ADAPTOR FROM ROTOR, ITEMS 4 AND 7, REMOVE BLADES, ITEM 6. INSERT A PIECE OF MATERIAL ABOUT .06" THICK (1.5mm) INTO BLADE SLOT. IT SHOULD EXTEND ABOUT 1/2" (12mm) ABOVE ROTOR SURFACE. PLACE IN VISE WITH SOFT JAWS. THIS WILL PREVENT ROTOR FROM TURNING WHEN REMOVING ADAPTOR WITH A WRENCH.
3. PRESS ROTOR, ITEM 7, OUT OF BEARING, ITEM 2.

MOTOR REASSEMBLY

1. CLEAN AND LUBRICATE ALL PARTS.
2. REPLACE PARTS AS NEEDED.
3. REASSEMBLE PARTS IN REVERSE ORDER.

Figure 13 6200800: MOTOR ASSEMBLY, SC-400 & MOTOR ASSEMBLY PROCESS

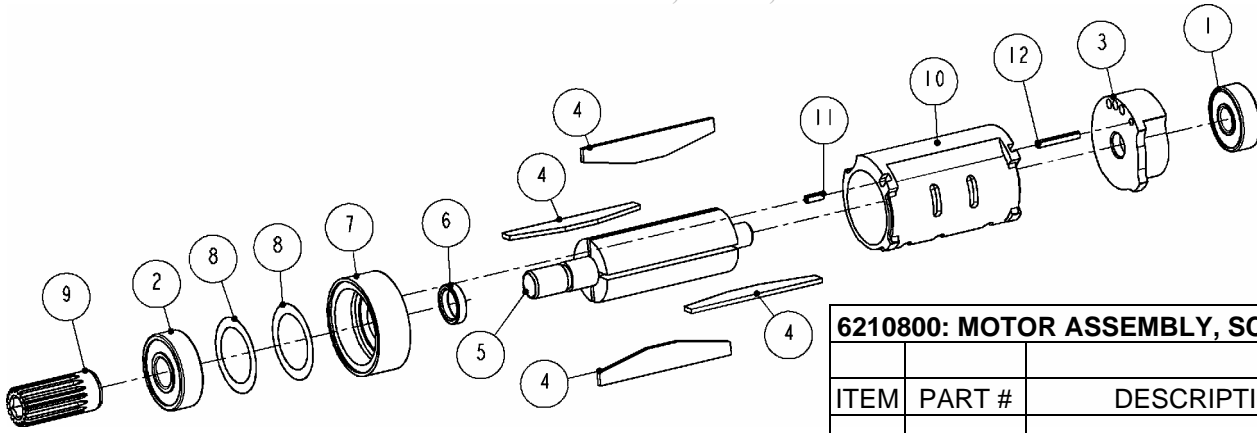

6210800: MOTOR ASSEMBLY, SC-550 & SC-650			
ITEM	PART #	DESCRIPTION	QTY
1	3072380	BEARING	1
2	3122000	BEARING	1
3	6201590	PLATE, REAR BEARING	1
4	6211520	BLADE, MOTOR	4
5	6211530	ROTOR	1
6	6211540	SPACER, ROTOR	1
7	6211550	PLATE, FRONT BEARING	1
8	6211560	SHIM	2
9	6211570	GEAR	1
10	6211610	CYLINDER	1
11	8611540	ROLL PIN	1
12	8611600	ROLL PIN	1

Figure 14 6210800: AIR MOTOR ASSEMBLY, SC-550 & SC-650

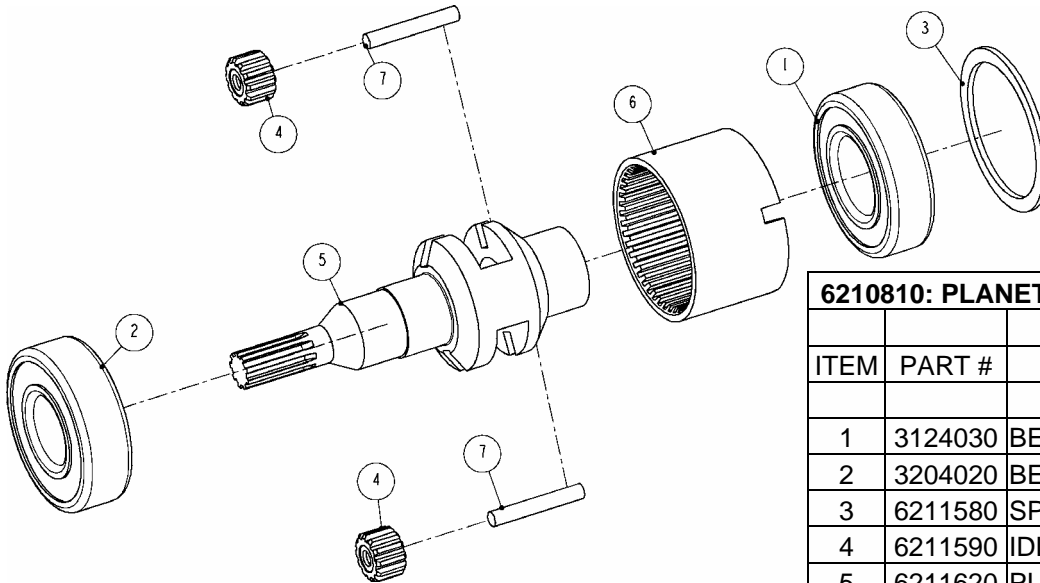

6210810: PLANETARY GEAR, SC-550 & SC-650			
ITEM	PART #	DESCRIPTION	QTY
1	3124030	BEARING	1
2	3204020	BEARING	1
3	6211580	SPACER	1
4	6211590	IDLER GEAR ASSEMBLY	2
5	6211620	PLANETARY CARRIER	1
6	6211630	GEAR, RING	1
7	8620060	PIN, PLANETARY GEAR	2

Figure 15 6210810: PLANETARY GEAR ASSEMBLY, SC-550 & SC-650

SC-400, SC-550, SC-650
BLADE GUARD AND DEPTH GAUGE

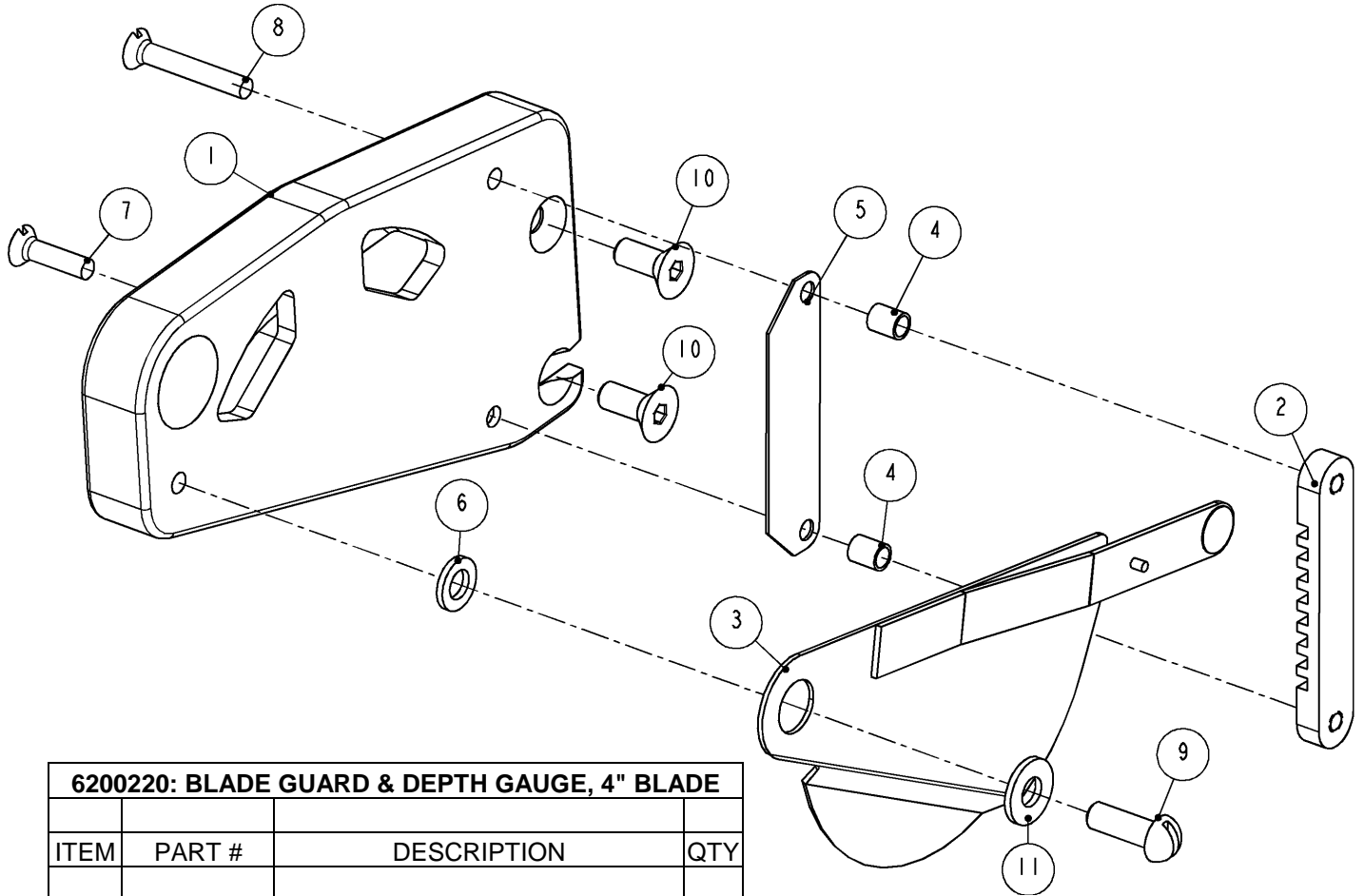

6200220: BLADE GUARD & DEPTH GAUGE, 4" BLADE			
ITEM	PART #	DESCRIPTION	QTY
1	6201130	GUARD, BLADE 4.0"	1
2	6201140	BRIDGE, 4" BLADE	1
3	6201150	DEPTH GAUGE, 4" BLADE	1
4	6201180	SPACER, BRIDGE	2
5	6201190	PLATE, FRICTION	1
6	6201200	WASHER	1
7	8010060	SCREW	1
8	8010100	SCREW	1
9	8031060	SCREW	1
10	8241050	SCREW	2
11	8505100	WASHER	1

Figure 16 6200220: GUARD AND DEPTH GAUGE, 4.0" BLADE

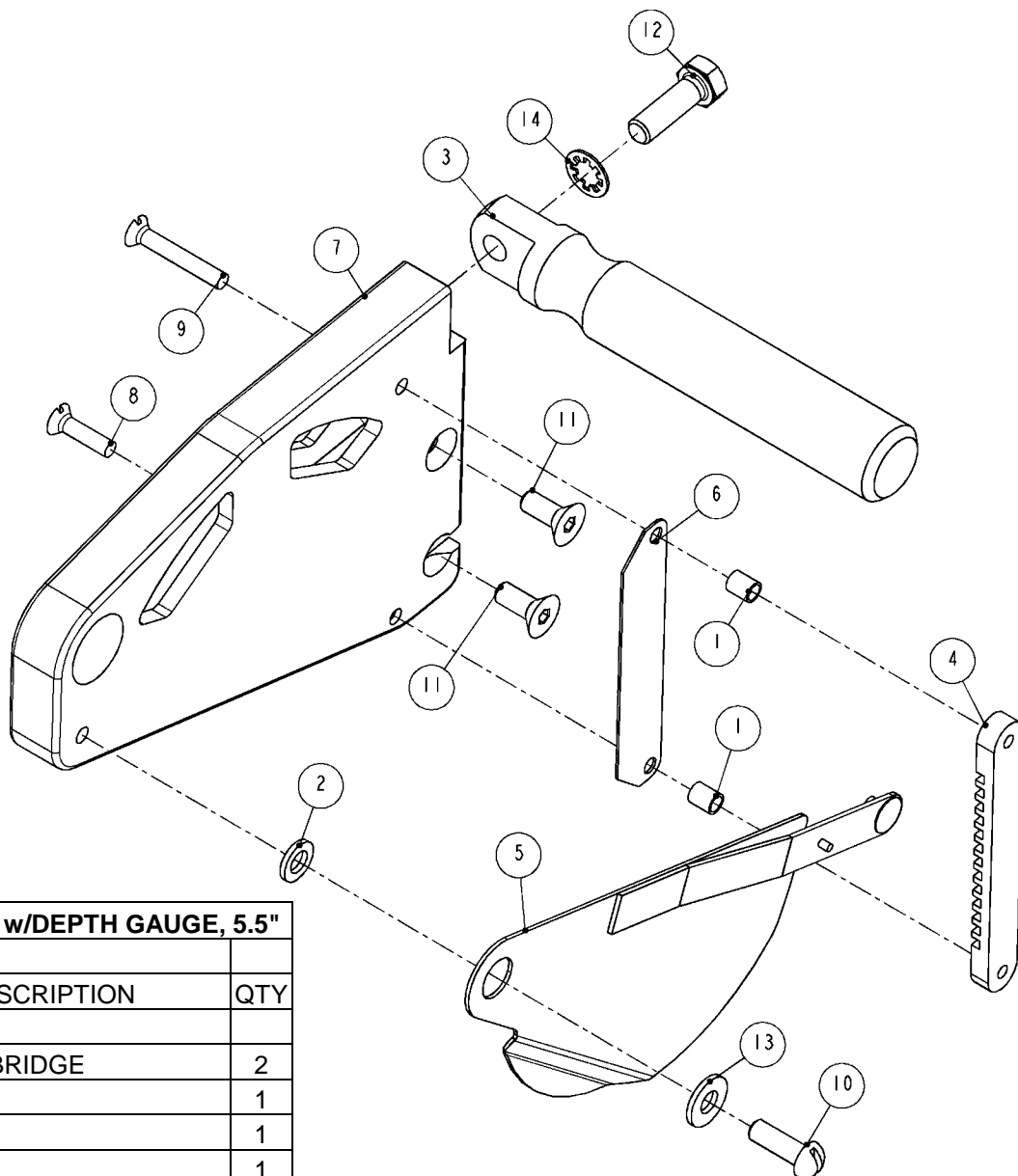

6210220: BLADE GUARD w/DEPTH GAUGE, 5.5"			
ITEM	PART #	DESCRIPTION	QTY
1	6201180	SPACER, BRIDGE	2
2	6201200	WASHER	1
3	6211030	HANDLE	1
4	6211040	BRIDGE	1
5	6211050	DEPTH GAUGE, 5.5" BLADE	1
6	6211070	PLATE, FRICTION	1
7	6211110	GUARD, BLADE 5.5"	1
8	8010060	SCREW	1
9	8010100	SCREW	1
10	8031060	SCREW	1
11	8241050	SCREW	2
12	8413080	SCREW	1
13	8505100	WASHER	1
14	8507150	WASHER	1

Figure 17 6210220: GUARD AND DEPTH GAUGE, 5.5" BLADE

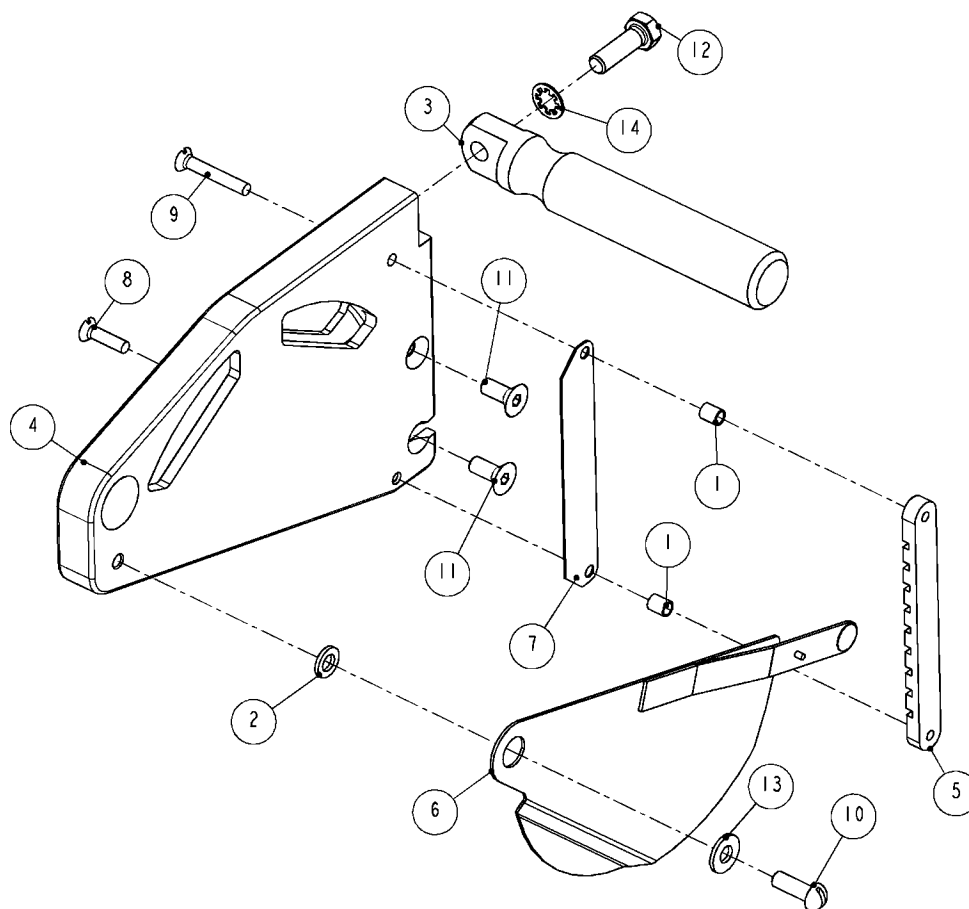

6220220: GUARD AND DEPTH GAUGE, 6.5"			
ITEM	PART #	DESCRIPTION	QTY
1	6201180	SPACER, BRIDGE	2
2	6201200	WASHER	1
3	6211030	HANDLE	1
4	6221030	GUARD	1
5	6221040	BRIDGE	1
6	6221050	DEPTH GAUGE, 6.5" BLADE	1
7	6221070	PLATE, FRICTION	1
8	8010060	SCREW	1
9	8010100	SCREW	1
10	8031060	SCREW	1
11	8241050	SCREW	2
12	8413080	SCREW	1
13	8505100	WASHER	1
14	8507150	WASHER	1

Figure 18 6220220: GUARD AND DEPTH GAUGE, 6.5" BLADE

SC-400, SC-550, SC-650
FRONT HANDLE (OPTIONAL)

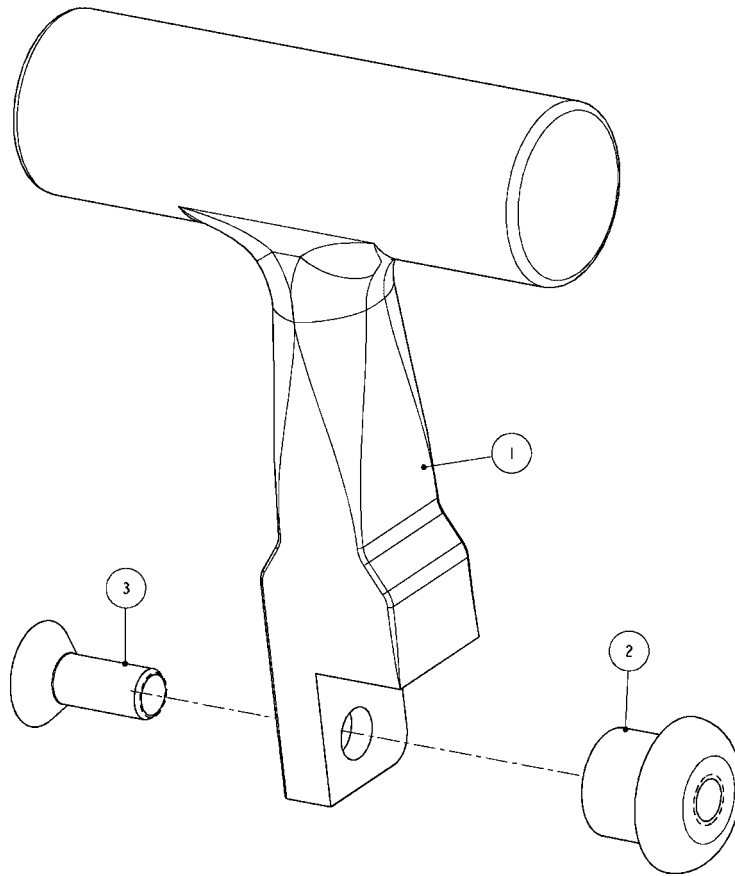

6201640: FRONT HANDLE (OPTIONAL)			
ITEM	PART #	DESCRIPTION	QTY
1	6201620	FRONT HANDLE	1
2	6201630	NUT	1
3	8245080	SCREW	1

Figure 19 6201640: FRONT HANDLE (OPTIONAL)

[ENGLISH]

GENERAL INFORMATION

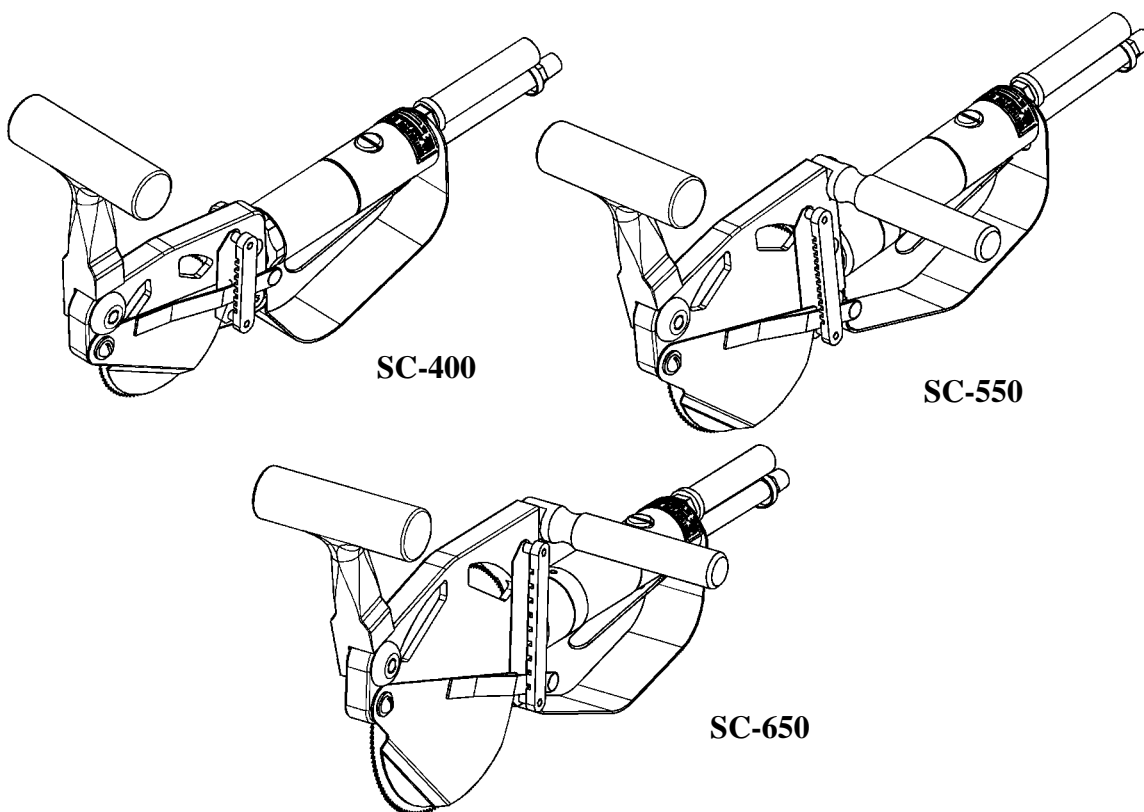

MODELS

SC-400 ALL PURPOSE BREAKING SAW (6200000)

SC-550 ALL PURPOSE BREAKING SAW (6210000)

SC-650 ALL PURPOSE BREAKING SAW (6220000)

SERVICE CENTERS

KENTMASTER LTD. (U.K)
16 AVONBANK INDUSTRIAL CENTRE
WEST TOWN ROAD
AVONMOUTH - BRISTOL BS11 9DE
UNITED KINGDOM

☎ TELEPHONE: ++ 44- (0) 117- 9235035
FAX: ++ 44- (0) 117- 9829010

KENTMASTER MFG. CO., INC.
1801 SOUTH MOUNTAIN AVE.
MONROVIA, CALIFORNIA 91016
UNITED STATES OF AMERICA

☎ TELEPHONE: (626) 359-8888
FAX: (626) 303-5151

NOTICE TO EMPLOYER AND PURCHASER OF TOOL
NOTICE TO SAFETY DIRECTOR

You have purchased a powerful tool that, if misused, can cause severe injury and harm to your employees. You must instruct your employees in the safe and proper use of this tool and to follow the safety procedures and instructions that have been supplied by the manufacturer of this tool. Please follow the following instructions.



1. Instruct tool operators to test the tool each day before using it to be sure it does not malfunction. Remove and repair any tool that malfunctions.
2. Instruct tool operators to immediately stop using a tool that malfunctions or is defective.
3. Instruct personnel to immediately remove all tools that malfunction. Be sure to disconnect tool from power supply.
4. Instruct all personnel to stay clear of tool, and not to stand or walk in front of, or next to tool when in use.
5. Point out to all personnel the dangers related to the misuse of tool and the importance of following safety procedures and instructions.
6. Do not make, or allow others to make, alterations or modifications to this tool. Replace all lost or illegible labels.
7. Follow all safety, installation and maintenance instructions provided with this tool. Establish proper safety procedures in accordance with local and national requirements to prevent accidental energizing of tool that can cause injuries.
8. If this tool is sold or change in ownership takes place, you must provide the new owner all safety instructions, notices and maintenance instructions you were originally provided. You can obtain additional copies of the instructions from Kentmaster, free of charge upon request.
9. Give copies of instructions to: **(A) Tool Operators**
(B) Maintenance Supervisor
(C) Clean-up Supervisor

DECLARATION OF CONFORMITY

DECLARATION OF CONFORMITY

DECLARATION DE CONFORMITE -DECLARACION DE CONFORMIDAD- ERKLARUNG BEZUGLICH EINHALTUNG DER VORSCHRIFTEN
DICHIARAZIONE DI CONFORMITA . CONFORMITEITSVERKLARING

MANUFACTURED BY:

FABRIQUE PAR:
FABRICADA POR:
HERGESTELLTVON:
FABBRICATO DA:
VERVAARDIGD DOOR:

KENTMASTER MFG CO., INC.
1801 SOUTH MOUNTAIN AVE.
MONROVIA, CALIFORNIA 91016
UNITED STATES OF AMERICA
TELEPHONE (626) 359-8888 FAX (626) 303-5151

TYPE / SERIES: ALL PURPOSE BONE SAW

TYPE / SERIE:
TIPO / SERIE:
TYP / SERIE:
TIPO / SERIE:
TYPE / SERIE:

MODEL: SC-400, SC-550, SC-650

MODELE:
MODELO:
MODELL:
MODELLO:
MODEL:

SERIAL NO. RANGE: XXXXX

N SERIE: • GAMA DE No. DE SERIE: • SERIEN-NR.-BEREICH: • NUMERI DI SERIE: • SERIENUMMERS:

This product complies with the following European Community Directives:

Ce produit est conforme aux directives de la Communauté européenne suivantes:
Este producto cumple con las siguientes Directrices de la Comunidad Europea:
Dieses Produkt erfüllt die folgenden Vorschriften der Europäischen Gemeinschaft:
Questo prodotto è conforme alle seguenti direttive CEE:
Dit produkt voldoet aan de volgende EG-richtlijnen:

89/392/EEC, 91/368/EEC, 93/44/EEC, 93/68/EEC

The following Standards were used to verify compliance with the Directives:

Les normes suivantes ont été utilisées pour vérifier la conformité avec les Directives:
Las siguientes Normas se usaron para verificar el cumplimiento de las Directrices:
Folgende Normen wurden angewandt, um Erfüllung der Vorschriften zu bestätigen:
Per verificare la conformità del prodotto alle direttive sono stati usati i seguenti standard:
De volgende normen zijn gebruikt om naleving van de richtlijnen te bevestigen:

EN 292

Approved by: _____

RALPH KARUBIAN MONROVIA, CA. U.S.A

(Engineering Manager) (Directeur technique) (gerente de ingenieria) (verantwortlicher Konstruktionsleiter) (Responsabile tecnico) (ondersteunend technisch manager)

Date: AUG - 1 - 1995

Kentmaster Worldwide Location

Kentmaster Equipment (Aust) PTY.LTD.

Unit 2,24 Central Court
Browns Plains Qld. 4118
Australia

Telephone: (07) 3806-8400

Fax: (07) 3806-7933

Australia@Kentmaster.com

Kentmaster do Brasil, Ltda.

Av. Dr. Joao Teodoro No. 805
Bairro De Vila Rezende
13405-240 Piracicaba, SP,
Brazil

Telephone #1: (019) 3 413 3113

Telephone #2: (019)983-4973

Fax: (019) 3 413 3113

Brazil@Kentmaster.com

Kentmaster (IRL) LTD.

Benamore, Dublin Road.
Roscrea,
CO, Tipperary,
Ireland

Telephone: (353) 0505-23292

Fax: (353) 0505-23299

Ireland@Kentmaster.com

Kentmaster Equipment (NZ) LTD.

5 Cooper Street
Havelock North
New Zealand

Telephone #1: (64) 6 8777 857

Telephone #2: 0800 KENTMASTER

Fax: (64) 6 8777 858

NewZealand@Kentmaster.com

Kentmaster South Africa (PTY) LTD.

Johannesburg - S. Africa
Unit 54 Sunnyrock Park
Sunrock Close, Germiston
South Africa

Telephone: (27) 11-455-3748

Fax: (27) 11-455-3749

SouthAfrica@Kentmaster.com

Kentmaster (UK) LTD.

Unit 16 Avonbank Ind. Centre
West Town Rd, Avonmouth-Bristol,
BS11 9DE
England

Telephone: (44) 117-923-5035

Fax: (44)-117-932-9010

UK@Kentmaster.com

Kentmaster Mfg. Co., Inc.
1801 South Mountain Ave.
Monrovia, CA, 91016
USA

Telephone #1: (626) 359-8888

Telephone #2: (800) 421-1477

Fax: (626) 303-5151

info@Kentmaster.com

Kentmaster Omaha
4417 South 139th Street
Omaha, NE, 68137
USA

Telephone #1: (402) 896-3355

Telephone #2: (800) 367-3181

Fax: (402) 896-3311

Omaha@Kentmaster.com

INDEX

OPERATING AND SAFETY INSTRUCTIONS 2

OPERATING INSTRUCTIONS 3

MAINTENANCE 3

SERVICE 4

PARTS BOOK..... 4

MODEL SC-400, SCRIBE SAW 5

MODEL SC-550 & SC-650, SCRIBE SAW..... 7

GEARS AND GEAR HOUSING ASSEMBLY 9

SPECIAL TOOLS (OPTIONAL)..... 11

GEAR HOUSING DISASSEMBLY 12

GEAR HOUSING REASSEMBLY 12

AIR MOTOR ASSEMBLY 13

MOTOR DISASSEMBLY 13

MOTOR REASSEMBLY..... 13

BLADE GUARD AND DEPTH GAUGE..... 15

FRONT HANDLE (OPTIONAL)..... 18

DECLARATION OF CONFORMITY 21

Kentmaster Worldwide Location 22

INDEX..... 23

FIGURES - INDEX..... 23

FIGURES - INDEX

Figure 1 SC- 4

Figure 2 MODEL SC-400 5

Figure 3 BOM FOR MODEL SC-400 6

Figure 4 MODEL SC-500 & SC-650 7

Figure 5 BOM FOR MODELS SC-500 & SC-650 8

Figure 6 6201250: GEAR HOUSING ASSEMBLY, SC-400 & SC-550 9

Figure 7 6201250: GEAR HOUSING ASSEMBLY, SC-650 9

Figure 8 6200230: DRIVEN CARTRIDGE ASSEMBLY 10

Figure 9 6220200: DRIVE CARTRIDGE ASSEMBLY, SC-400 & SC-550 10

Figure 10 6220200: DRIVE CARTRIDGE ASSEMBLY, SC-650 11

Figure 11 SC-, SPECIAL TOOLS (OPTIONAL)..... 11

Figure 12 GEAR HOUSING ASSEMBLY PROCESS 12

Figure 13 6200800: MOTOR ASSEMBLY, SC-400 & MOTOR ASSEMBLY PROCESS 13

Figure 14 6210800: AIR MOTOR ASSEMBLY, SC-550 & SC-650 14

Figure 15 6210810: PLANETARY GEAR ASSEMBLY, SC-550 & SC-650 14

Figure 16 6200220: GUARD AND DEPTH GAUGE, 4.0" BLADE 15

Figure 17 6210220: GUARD AND DEPTH GAUGE, 5.5" BLADE 16

Figure 18 6220220: GUARD AND DEPTH GAUGE, 6.5" BLADE 17

Figure 19 6201640: FRONT HANDLE (OPTIONAL) 18