

# 153

**INCLUDING: OPERATION, INSTRUCTION, INSTALLATION, MAINTENANCE AND PARTSBOOK**

---

**IMPORTANT: READ THIS MANUAL CAREFULLY BEFORE INSTALLING, OPERATING OR  
SERVICING THIS TOOL.**



---

## **BEEF BRISKET SAW**



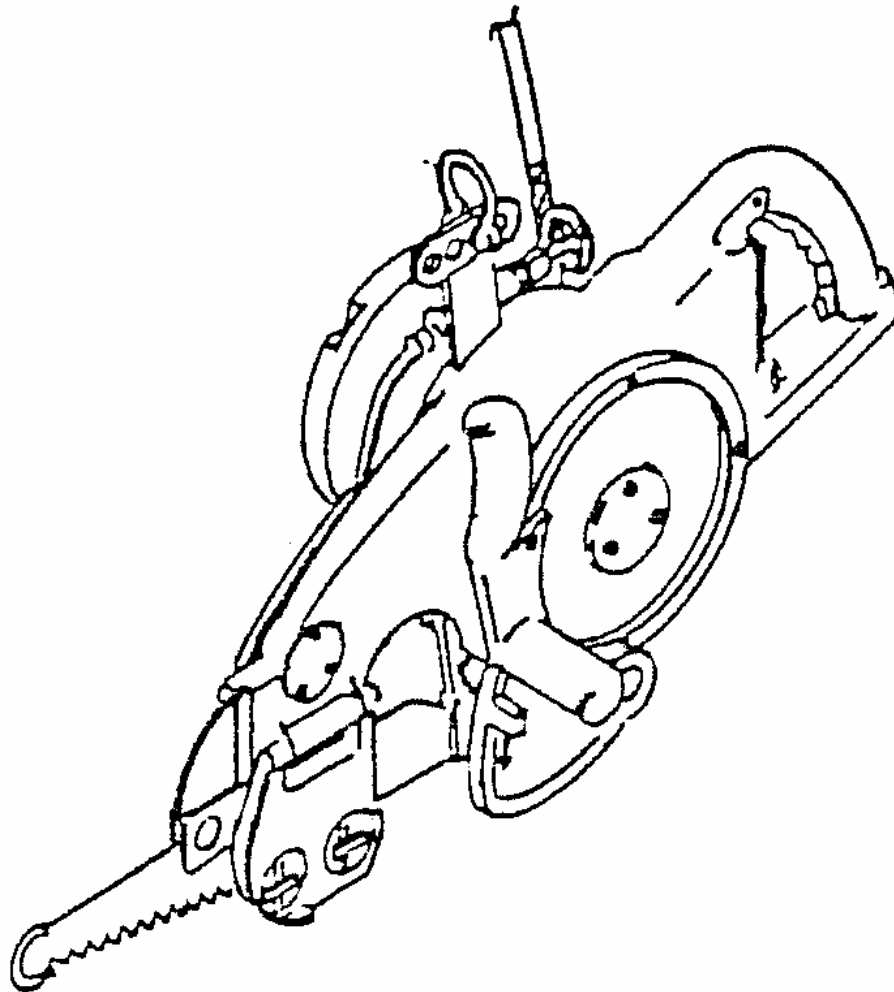



### **TOOL DATA**

MODEL: KENTMASTER 153  
ASSEMBLY NO: 1530000  
TYPE: ELECTRICAL OPERATED  
NET WEIGHT: 106 LB (48 KG)  
MOTOR HORSEPOWER: 2HP / 50Hz, 60Hz



|                                                                                                  |                                                                                                                   |
|--------------------------------------------------------------------------------------------------|-------------------------------------------------------------------------------------------------------------------|
|  <b>WARNING</b> | = Hazards or unsafe practices which could result in severe personal injury, death or substantial property damage. |
|  <b>CAUTION</b> | = Hazards or unsafe practices which could result in minor personal injury, product or property damage.            |
|  <b>NOTICE</b>  | = Important installation, operation or maintenance information.                                                   |

## **OPERATING AND SAFETY INSTRUCTIONS**

-  **WARNING** DO NOT OPERATE THIS TOOL UNTIL YOU HAVE READ AND UNDERSTOOD THE SAFETY INSTRUCTIONS AND OPERATING MANUALS.
-  **WARNING** DO NOT OPERATE THIS TOOL UNTIL YOU HAVE RECEIVED TRAINING IN THE HANDLING, OPERATION AND USE OF THIS TOOL.
-  **WARNING** STOP USING A MALFUNCTIONING OR DEFECTIVE TOOL IMMEDIATELY. REPORT ANY PROBLEMS OR DEFECTS TO YOUR SUPERVISOR FOR REMOVAL OF THE TOOL FROM SERVICE.
-  **WARNING** DO NOT ATTEMPT TO REPAIR THE TOOL YOURSELF.
-  **WARNING** DO NOT ALLOW UNAUTHORIZED PERSONS TO USE TOOL.
-  **WARNING** REMOVE AND DISCONNECT POWER FROM THE TOOL WHEN TOOL IS LEFT UNATTENDED OR IS NOT IN USE.
-  **WARNING** NEVER TIE DOWN, BYPASS, ALTER OR MODIFY THE ACTIVATING SWITCHES OR TRIGGERS OF THIS TOOL.
-  **WARNING** NEVER MAKE ALTERATIONS OR MODIFICATIONS TO THIS TOOL.
-  **WARNING** BE CONSTANTLY AWARE AND ALERT FOR UNSAFE CONDITIONS AND REPORT THEM IMMEDIATELY TO YOUR SUPERVISOR.
-  **WARNING** NEVER PLACE YOUR HAND OR ANY PART OF YOUR BODY IN THE CUTTING PATH OF THE TOOL.
-  **WARNING** NEVER ALLOW ANYONE ELSE TO PLACE THEIR HANDS OR ANY PART OF THEIR BODY IN THE CUTTING PATH OF THE TOOL.
-  **WARNING** DO NOT ACTIVATE CONTROL SWITCHES OR TRIGGERS OF THIS TOOL UNLESS YOU INTEND TO TEST OR OPERATE THIS TOOL.
-  **WARNING** DO NOT USE THIS TOOL FOR ANY PURPOSE OTHER THAN IT'S INTENDED PURPOSE.
-  **CAUTION** WHEN OPERATING THIS TOOL WEAR THE PROTECTIVE GEAR AND SAFETY EQUIPMENT SUPPLIED TO YOU.
-  **WARNING** THE NOISE EMISSION (SOUND PRESSURE LEVEL) AT THE WORKSTATION MAY EXCEED 80 dB (A). EAR AND SOUND PROTECTION GEAR IS REQUIRED.

## SERVICE

1. KEEP GOOD RECORDS OF ALL SERVICE ACTIVITY AND INCLUDE TOOL IN PREVENTIVE MAINTENANCE PROGRAM.
2. USE ONLY GENUINE KENTMASTER REPLACEMENT PARTS TO ASSURE PROPER PERFORMANCE OF TOOL.
3. CONTACT THE KENTMASTER SUPPLIER NEAREST YOU FOR PARTS AND CUSTOMER SERVICE INFORMATION.

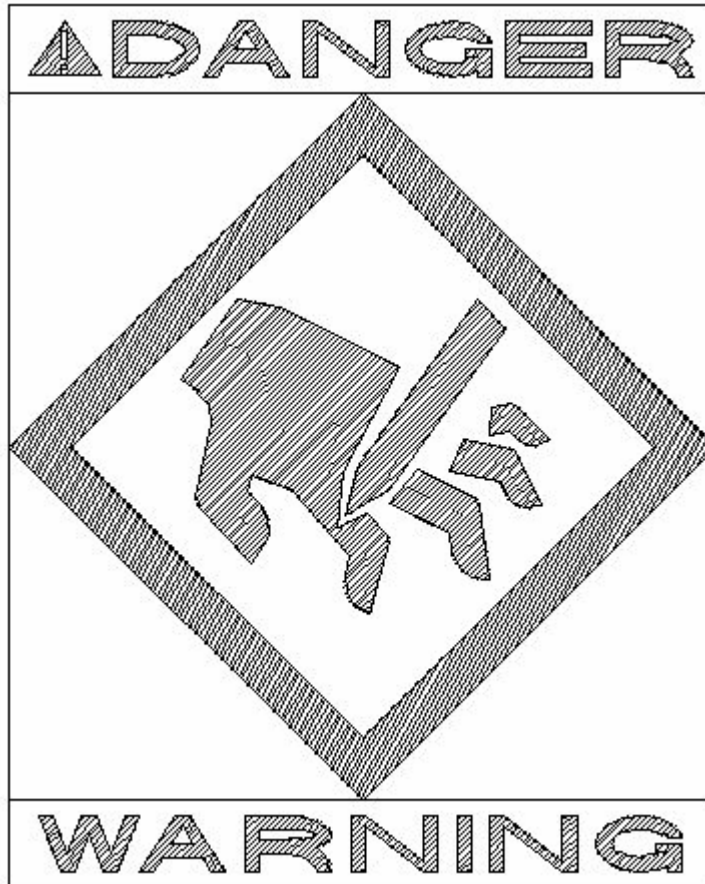

## PARTS BOOK

### "153" MAIN ASSEMBLY



**MOTOR ASSEMBLY**

|                                            |                                  |         |         |
|--------------------------------------------|----------------------------------|---------|---------|
| MOTOR ASS'Y 230V, 2HP, 1PH, 60HZ, 6.2AMPS  | 1501751-230-160                  | 2310020 | 1501713 |
| MOTOR ASS'Y 115V, 2HP, 1PH, 60HZ, 12.4AMPS | 1501751-115-160                  | 2310020 | 1501713 |
| MOTOR ASS'Y 416V, 2HP, 3PH, 50HZ, 3.9AMPS  | 1501753-416-350                  | 2310441 | 1501712 |
| MOTOR ASS'Y 208V, 2HP, 3PH, 50HZ, 7.8AMPS  | 1501753-208-350                  | 2310441 | 1501712 |
| MOTOR ASS'Y 380V, 2HP, 3PH, 50HZ, 4.3AMPS  | 1501757-380-350                  | 2311540 | 1501712 |
| MOTOR ASS'Y 220V, 2HP, 3PH, 50HZ, 7.4AMPS  | 1501757-220-350                  | 2311540 | 1501712 |
| MOTOR ASS'Y 230V, 2HP, 3PH, 50HZ, 6.4AMPS  | 1501756-230-350                  | 2311500 | 1501712 |
| MOTOR ASS'Y 115V, 2HP, 3PH, 50HZ, 12.8AMPS | 1501756-115-350                  | 2311500 | 1501712 |
| MOTOR ASS'Y 42V, 2HP, 3PH, 50HZ, 34.0AMPS  | 1501755                          | 2311480 | 1501712 |
| MOTOR ASS'Y 550V, 2HP, 3PH, 60HZ, 2.8AMPS  | 1501754                          | 2310460 | 1501712 |
| MOTOR ASS'Y 460V, 2HP, 3PH, 60HZ, 3.5AMPS  | 1501753-460-360                  | 2310441 | 1501712 |
| MOTOR ASS'Y 230V, 2HP, 3PH, 60HZ, 7.0AMPS  | 1501753-230-360                  | 2310441 | 1501712 |
| MOTOR ASS'Y 416V, 2HP, 3PH, 60HZ, 3.9AMPS  | 1501752-416-360                  | 2310360 | 1501712 |
| MOTOR ASS'Y 208V, 2HP, 3PH, 60HZ, 7.8AMPS  | 1501752-208-360                  | 2310360 | 1501712 |
|                                            |                                  |         |         |
| MOTOR OPTION DESCRIPTION                   | MOTOR ASSEMBLY<br>(ORDER NUMBER) | STATOR  | ROTOR   |
|                                            |                                  |         |         |
| <b>"153" MOTOR OPTIONS WITH STATOR</b>     |                                  |         |         |

**Figure 2 MOTOR ASSEMBLY**

**POWER SUPPLY**

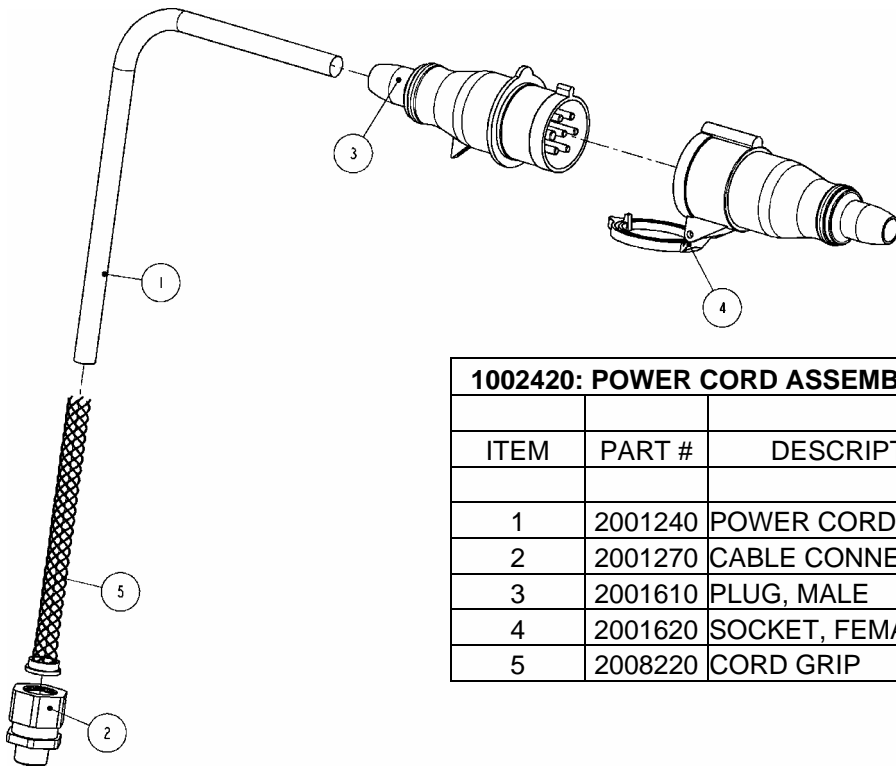

| <b>1002420: POWER CORD ASSEMBLY, NON 42V</b> |         |                 |     |
|----------------------------------------------|---------|-----------------|-----|
| ITEM                                         | PART #  | DESCRIPTION     | QTY |
| 1                                            | 2001240 | POWER CORD      | 1   |
| 2                                            | 2001270 | CABLE CONNECTOR | 1   |
| 3                                            | 2001610 | PLUG, MALE      | 1   |
| 4                                            | 2001620 | SOCKET, FEMALE  | 1   |
| 5                                            | 2008220 | CORD GRIP       | 1   |

**Figure 3 1002420: POWER SUPPLY, NON 42V, 3 PHASE**

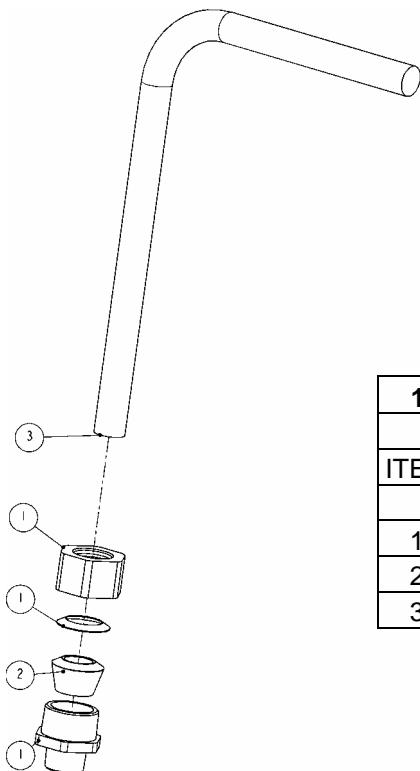

| <b>1002430: POWER CORD ASSEMBLY, 42V</b> |         |                 |     |
|------------------------------------------|---------|-----------------|-----|
| ITEM                                     | PART #  | DESCRIPTION     | QTY |
| 1                                        | 2001270 | CABLE CONNECTOR | 1   |
| 2                                        | 2001700 | GROMMET         | 1   |
| 3                                        | 2007030 | POWER CORD      | 1   |

**Figure 4 1002430: POWER SUPPLY, 42V, 3 PHASE**

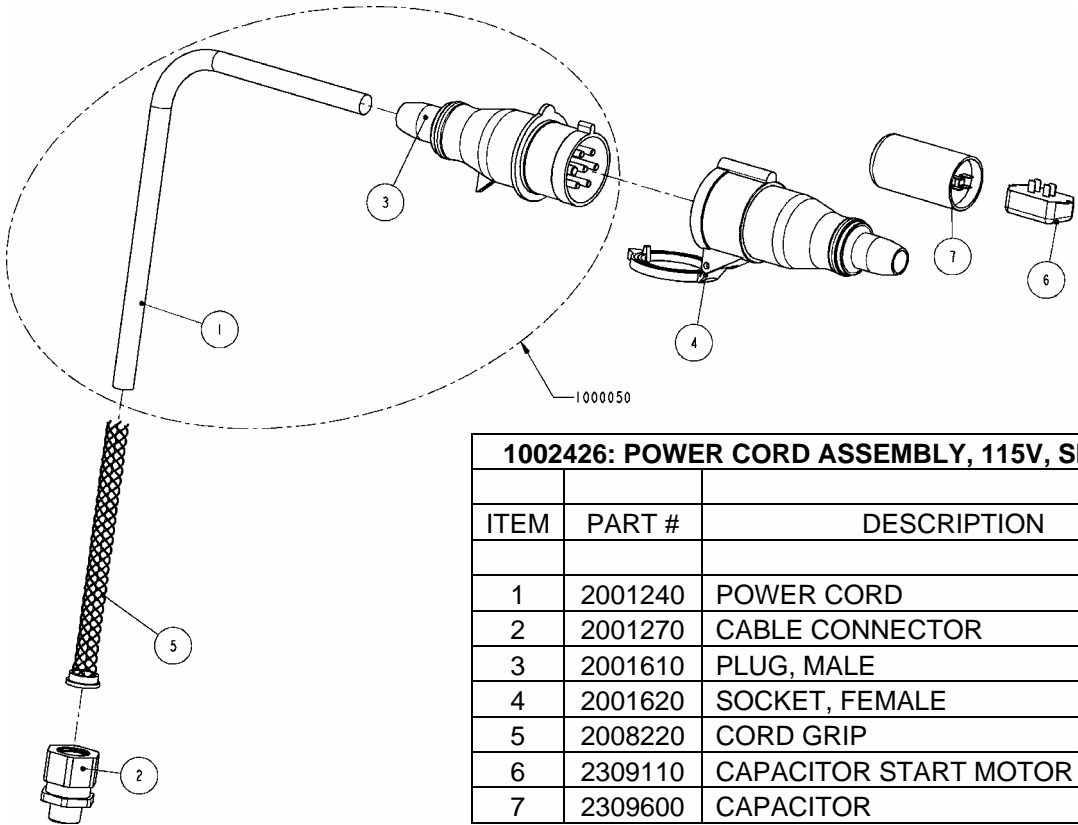

| 1002426: POWER CORD ASSEMBLY, 115V, SINGLE PHASE |         |                       |     |
|--------------------------------------------------|---------|-----------------------|-----|
| ITEM                                             | PART #  | DESCRIPTION           | QTY |
| 1                                                | 2001240 | POWER CORD            | 1   |
| 2                                                | 2001270 | CABLE CONNECTOR       | 1   |
| 3                                                | 2001610 | PLUG, MALE            | 1   |
| 4                                                | 2001620 | SOCKET, FEMALE        | 1   |
| 5                                                | 2008220 | CORD GRIP             | 1   |
| 6                                                | 2309110 | CAPACITOR START MOTOR | 1   |
| 7                                                | 2309600 | CAPACITOR             | 1   |

**Figure 5 POWER SUPPLY, 115V, SINGLE PHASE**

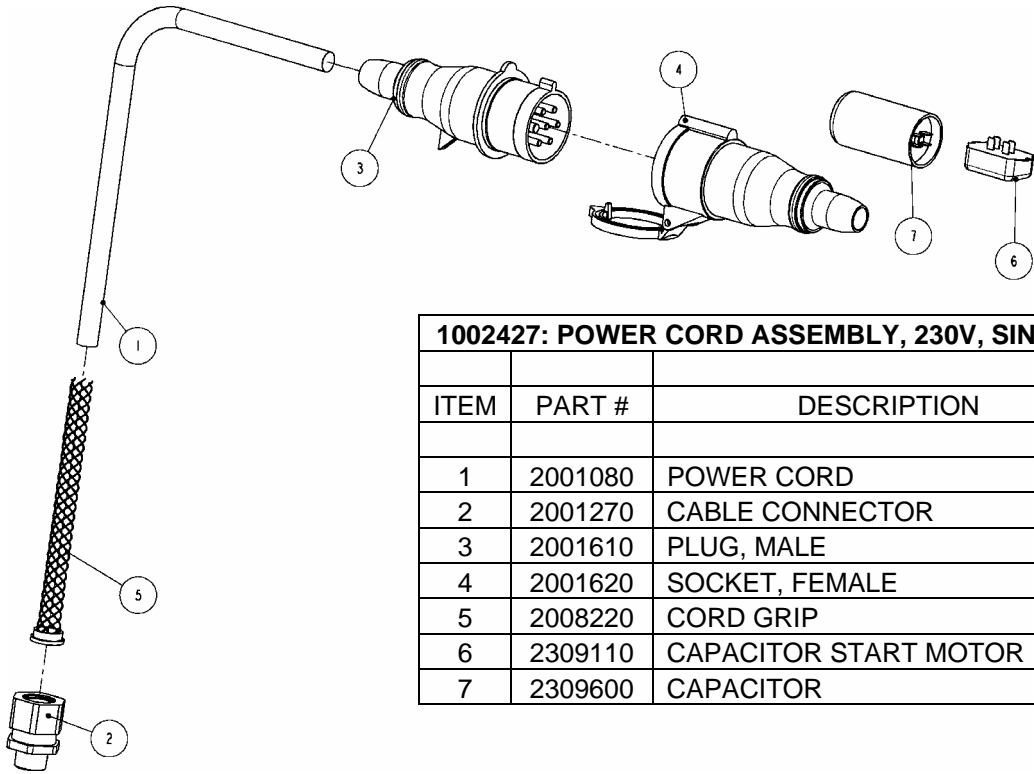

| 1002427: POWER CORD ASSEMBLY, 230V, SINGLE PHASE |         |                       |     |
|--------------------------------------------------|---------|-----------------------|-----|
| ITEM                                             | PART #  | DESCRIPTION           | QTY |
| 1                                                | 2001080 | POWER CORD            | 1   |
| 2                                                | 2001270 | CABLE CONNECTOR       | 1   |
| 3                                                | 2001610 | PLUG, MALE            | 1   |
| 4                                                | 2001620 | SOCKET, FEMALE        | 1   |
| 5                                                | 2008220 | CORD GRIP             | 1   |
| 6                                                | 2309110 | CAPACITOR START MOTOR | 1   |
| 7                                                | 2309600 | CAPACITOR             | 1   |

**Figure 6 POWER SUPPLY, 230V, SINGLE PHASE SWITCH ASSEMBLY**

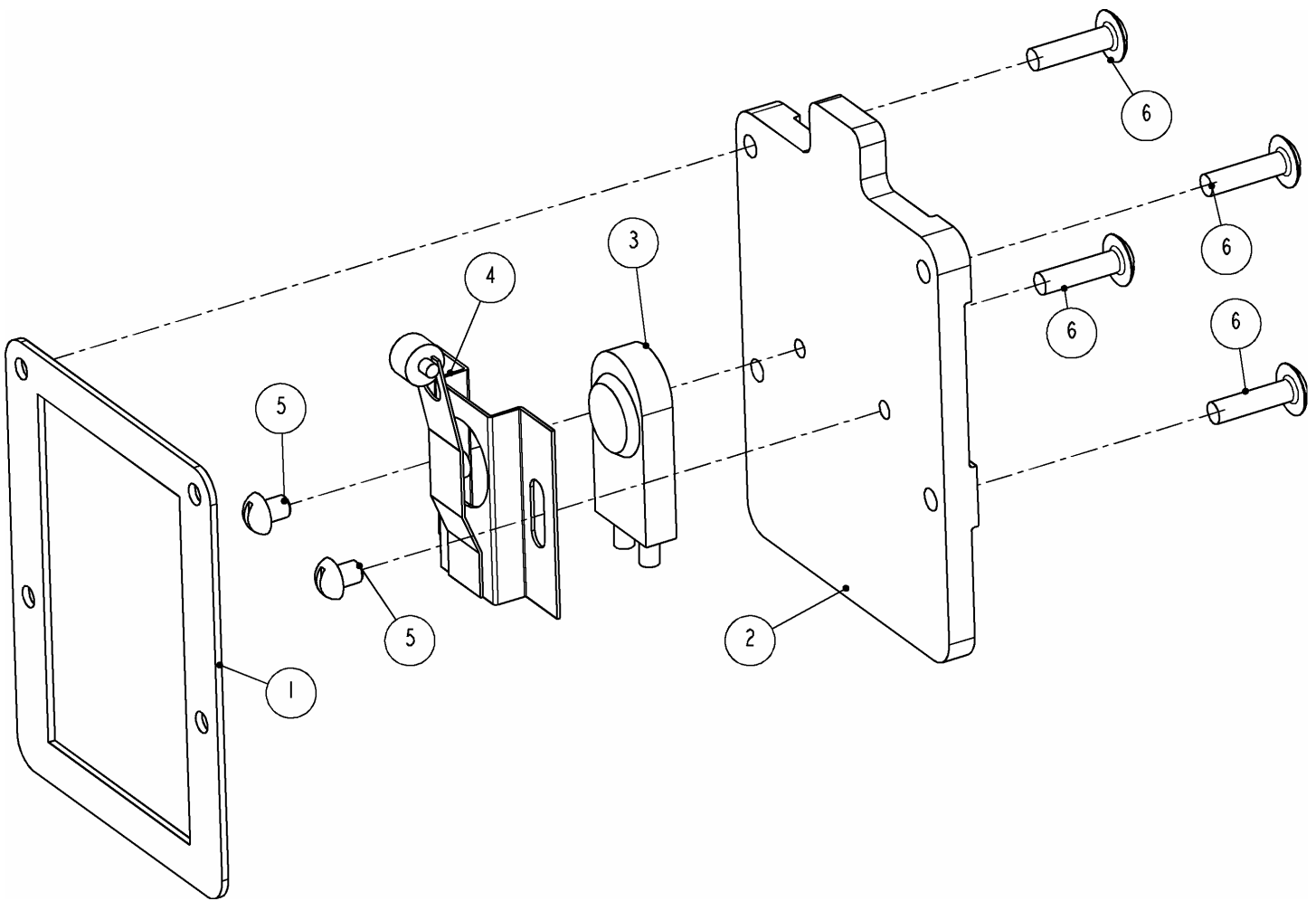

| 1502140: SWITCH PLATE ASSEMBLY |         |               |     |
|--------------------------------|---------|---------------|-----|
| ITEM                           | PART #  | DESCRIPTION   | QTY |
| 1                              | 1301860 | INSULATOR     | 1   |
| 2                              | 1502130 | PLATE, SWITCH | 1   |
| 3                              | 2000690 | SWITCH        | 1   |
| 4                              | 2000760 | TOP PLATE     | 1   |
| 5                              | 8030020 | SCREW         | 2   |
| 6                              | 8110060 | SCREW         | 4   |

**Figure 7 1502140: SWITCH PLATE ASSEMBLY**



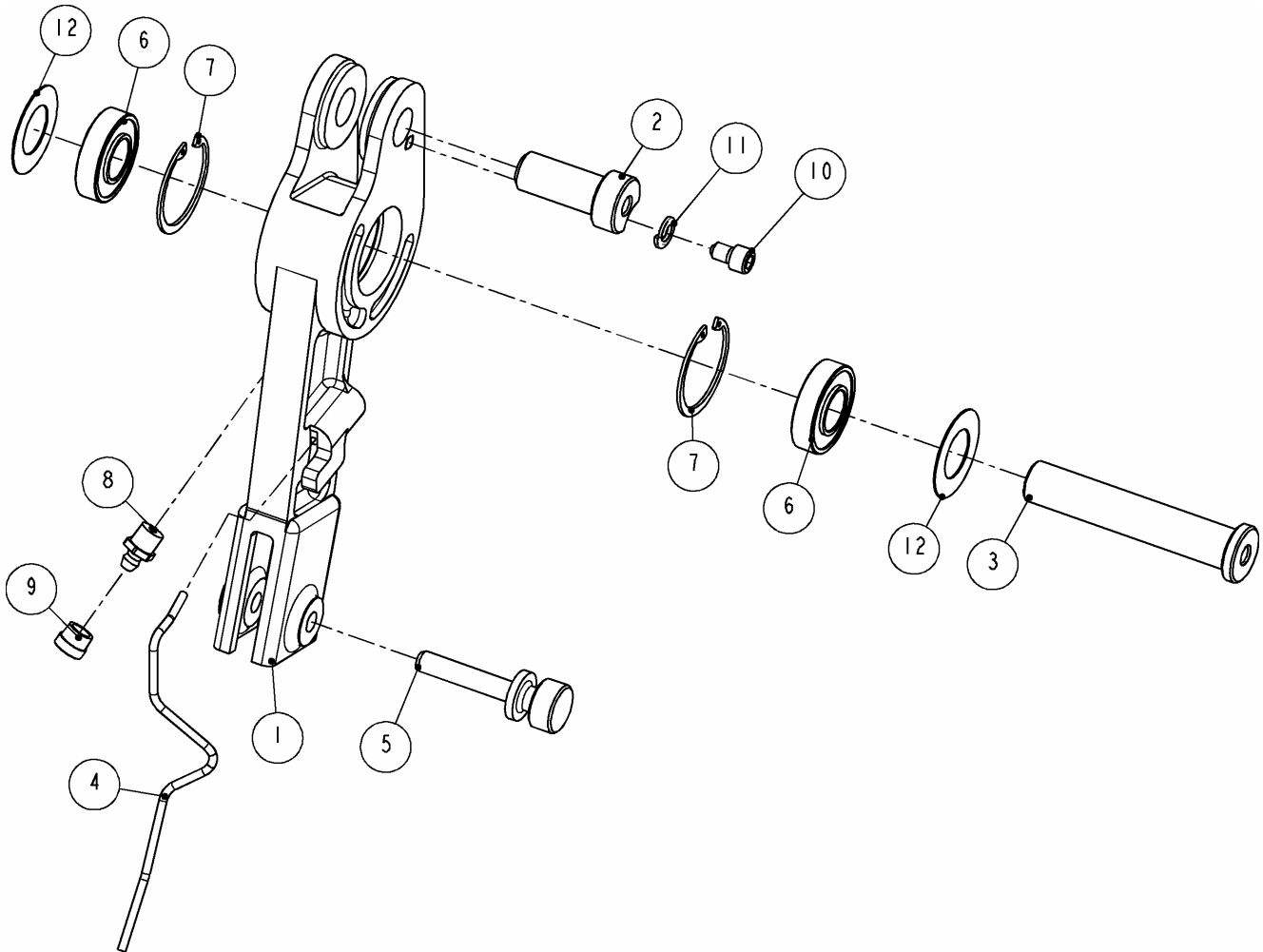

| 1501960: ROCKER ARM ASSEMBLY |         |                        |     |
|------------------------------|---------|------------------------|-----|
| ITEM                         | PART #  | DESCRIPTION            | QTY |
| 1                            | 1500080 | ROCKER ARM             | 1   |
| 2                            | 1500200 | PIN                    | 1   |
| 3                            | 1500210 | SHAFT                  | 1   |
| 4                            | 1500310 | SPRING, BLADE PIN LOCK | 1   |
| 5                            | 1500320 | PIN                    | 1   |
| 6                            | 3601200 | BEARING                | 2   |
| 7                            | 5001370 | RETAINING RING         | 2   |
| 8                            | 7016100 | LUBE FITTING           | 1   |
| 9                            | 7018400 | CAP, LUBE FITTING      | 1   |
| 10                           | 8211030 | SCREW                  | 1   |
| 11                           | 8506100 | WASHER                 | 1   |
| 12                           | 8705540 | SHIM                   | 2   |

**Figure 8 1501960: ROCKER ARM**

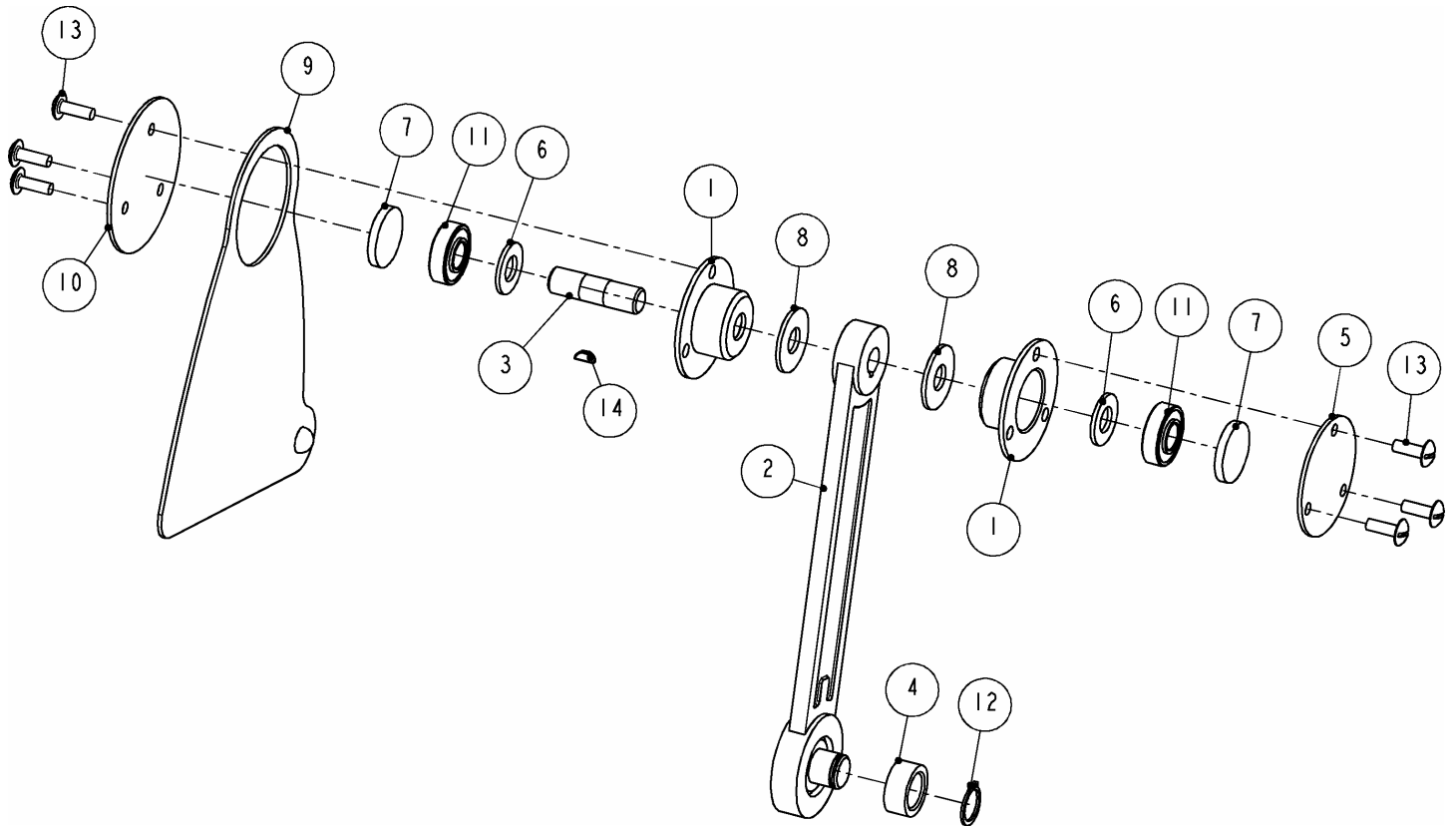

| 1501940: SUSPENSION ARM ASSEMBLY |         |                 |     |
|----------------------------------|---------|-----------------|-----|
| ITEM                             | PART #  | DESCRIPTION     | QTY |
| 1                                | 1500380 | CARTRIDGE       | 2   |
| 2                                | 1500400 | SUSPENSION ARM  | 1   |
| 3                                | 1500410 | SHAFT           | 1   |
| 4                                | 1500430 | BUSHING         | 1   |
| 5                                | 1500470 | COVER CARTRIDGE | 1   |
| 6                                | 1500480 | WASHER          | 2   |
| 7                                | 1500490 | SLUG            | 2   |
| 8                                | 1500500 | WASHER          | 2   |
| 9                                | 1500690 | COVER           | 1   |
| 10                               | 1500780 | COVER CARTRIDGE | 1   |
| 11                               | 3601160 | BEARING         | 2   |
| 12                               | 5100500 | RETAINING RING  | 1   |
| 13                               | 8108040 | SCREW           | 6   |
| 14                               | 8600130 | KEY             | 1   |

**Figure 9 1501940: SUSPENSION ARM**

**WIRING DIAGRAMS**

**3-PHASE, DIFFERENT CONTROL AND MOTOR VOLTAGE**

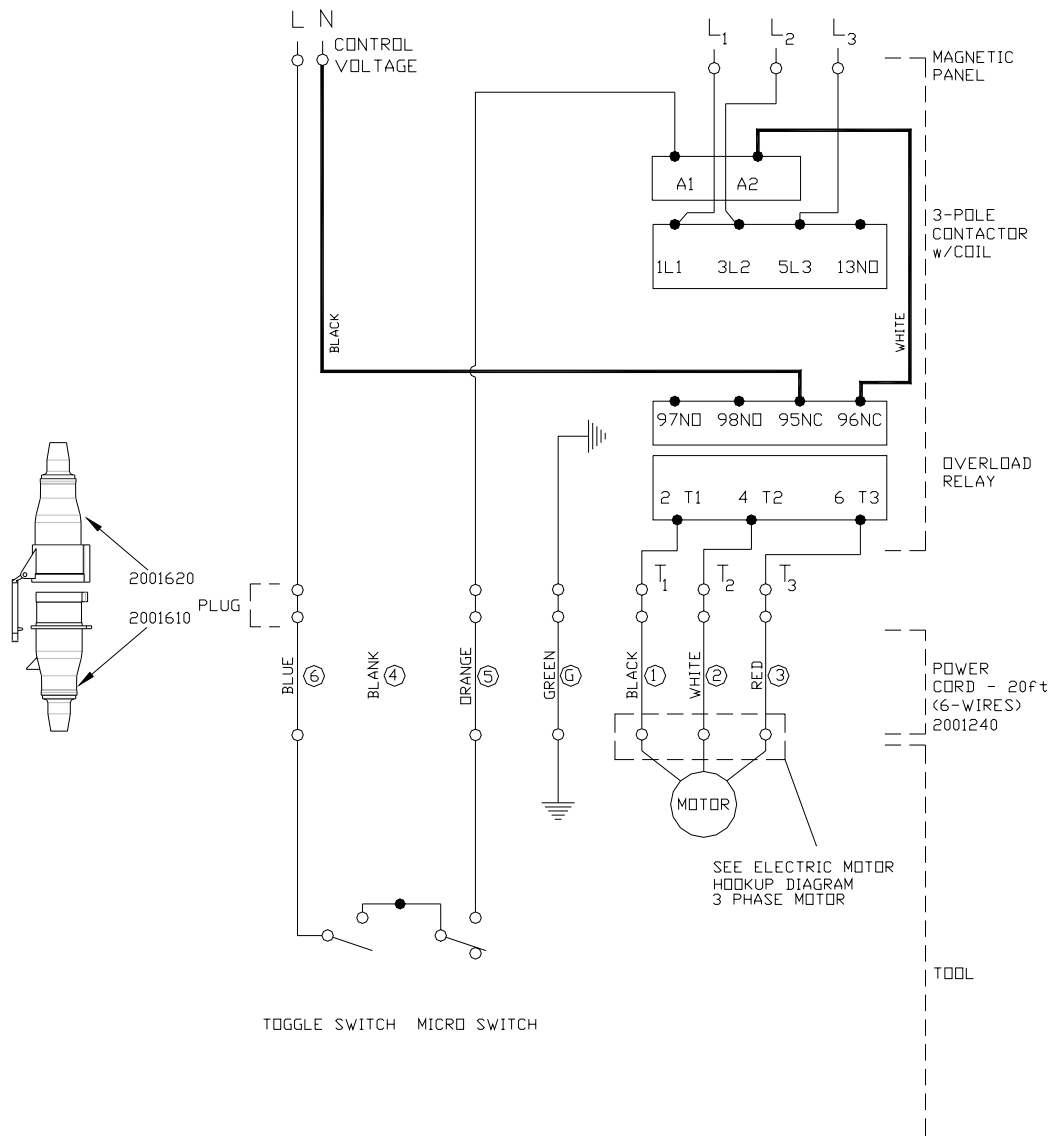

**NOTES:**

1. DO NOT ATTEMPT OR MAKE REPAIRS ON THE MACHINE WHILE POWER IS ON.
2. ALL ELECTRICAL WORK MUST BE PERFORMED BY A QUALIFIED ELECTRICIAN.
3. THE ELECTRICAL DIAGRAM SHOWS THE MACHINE IN THE "OFF" POSITION.
4. THE GROUND WIRE (GREEN) OF THE POWER CABLE IS CONNECTED TO THE FRAME OF THE MACHINE.

**To obtain the correct Kentmaster part number for 3-pole contactor and overload relay, please contact the Kentmaster representative.**

**Figure 10 WIRING DIAGRAM – different control and motor voltage**

**3-PHASE, SAME CONTROL AND MOTOR VOLTAGE**

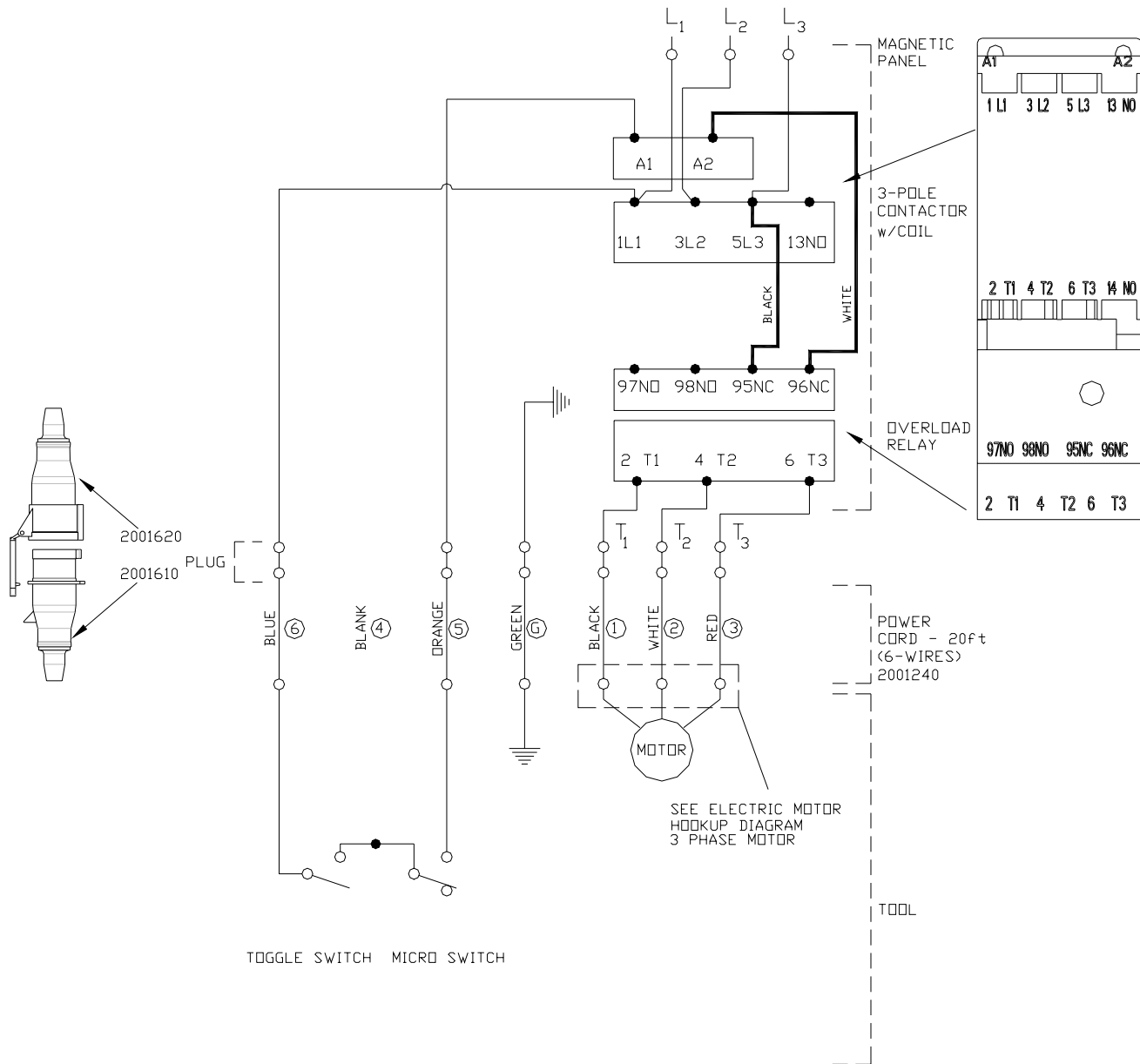

**NOTES:**

1. DO NOT ATTEMPT OR MAKE REPAIRS ON THE MACHINE WHILE POWER IS ON.
2. ALL ELECTRICAL WORK MUST BE PERFORMED BY A QUALIFIED ELECTRICIAN.
3. THE ELECTRICAL DIAGRAM SHOWS THE MACHINE IN THE "OFF" POSITION.
4. THE GROUND WIRE (GREEN) OF THE POWER CABLE IS CONNECTED TO THE FRAME OF THE MACHINE.

**To obtain the correct Kentmaster part number for 3-pole contactor and overload relay, please contact the Kentmaster representative.**

**Figure 11 WIRING DIAGRAM – same control and motor voltage**

**SINGLE PHASE, 115 VOLT**

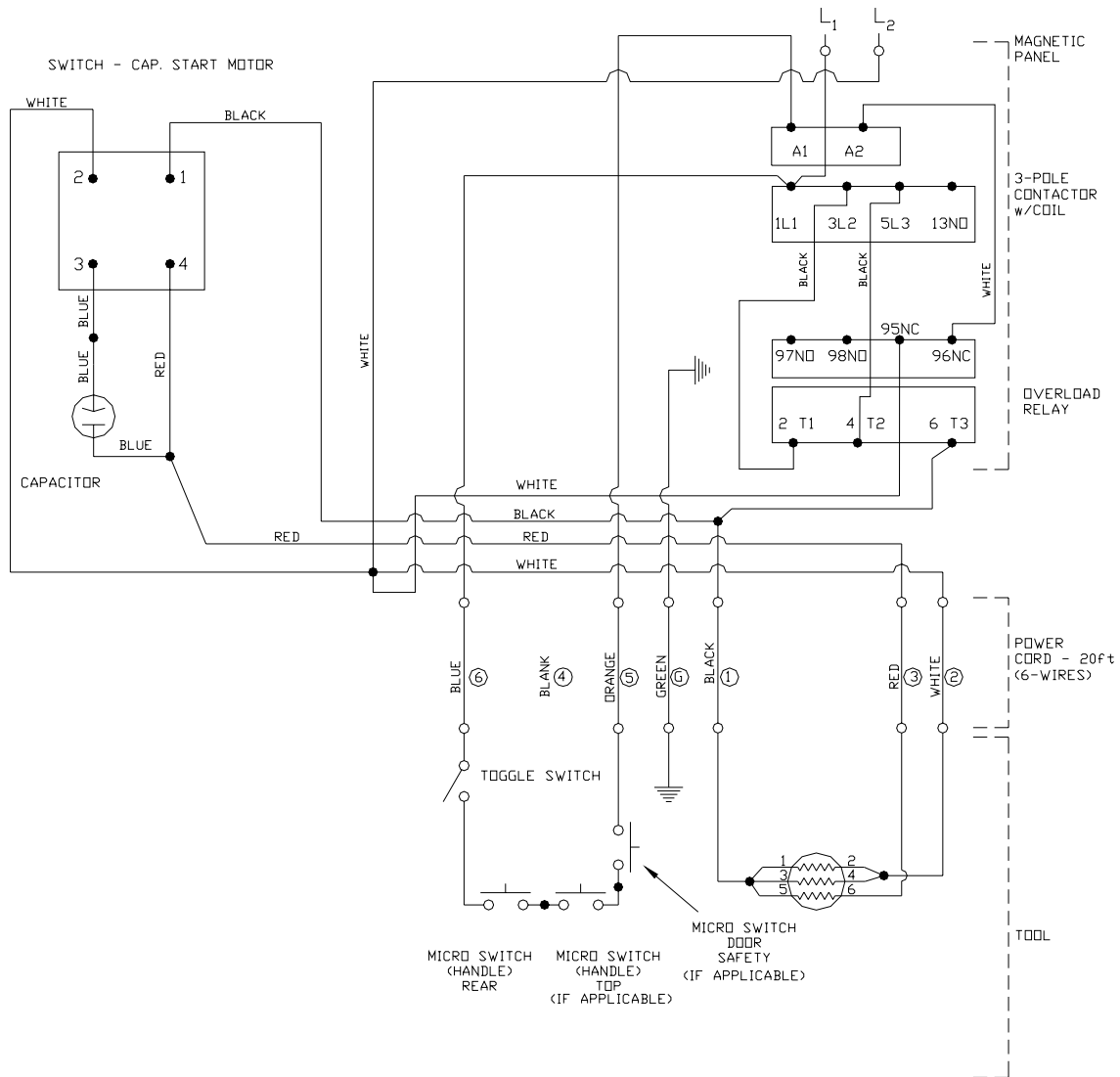

**NOTES:**

1. DO NOT ATTEMPT OR MAKE REPAIRS ON THE MACHINE WHILE POWER IS ON.
2. ALL ELECTRICAL WORK MUST BE PERFORMED BY A QUALIFIED ELECTRICIAN.
3. THE ELECTRICAL DIAGRAM SHOWS THE MACHINE IN THE "OFF" POSITION.
4. THE GROUND WIRE (GREEN) OF THE POWER CABLE IS CONNECTED TO THE FRAME OF THE MACHINE.

**To obtain the correct Kentmaster part number for 3-pole contactor and overload relay, please contact the Kentmaster representative.**

**Figure 12 WIRING DIAGRAM – 115 VOLT, SINGLE PHASE**

**SINGLE PHASE, 230 VOLT**

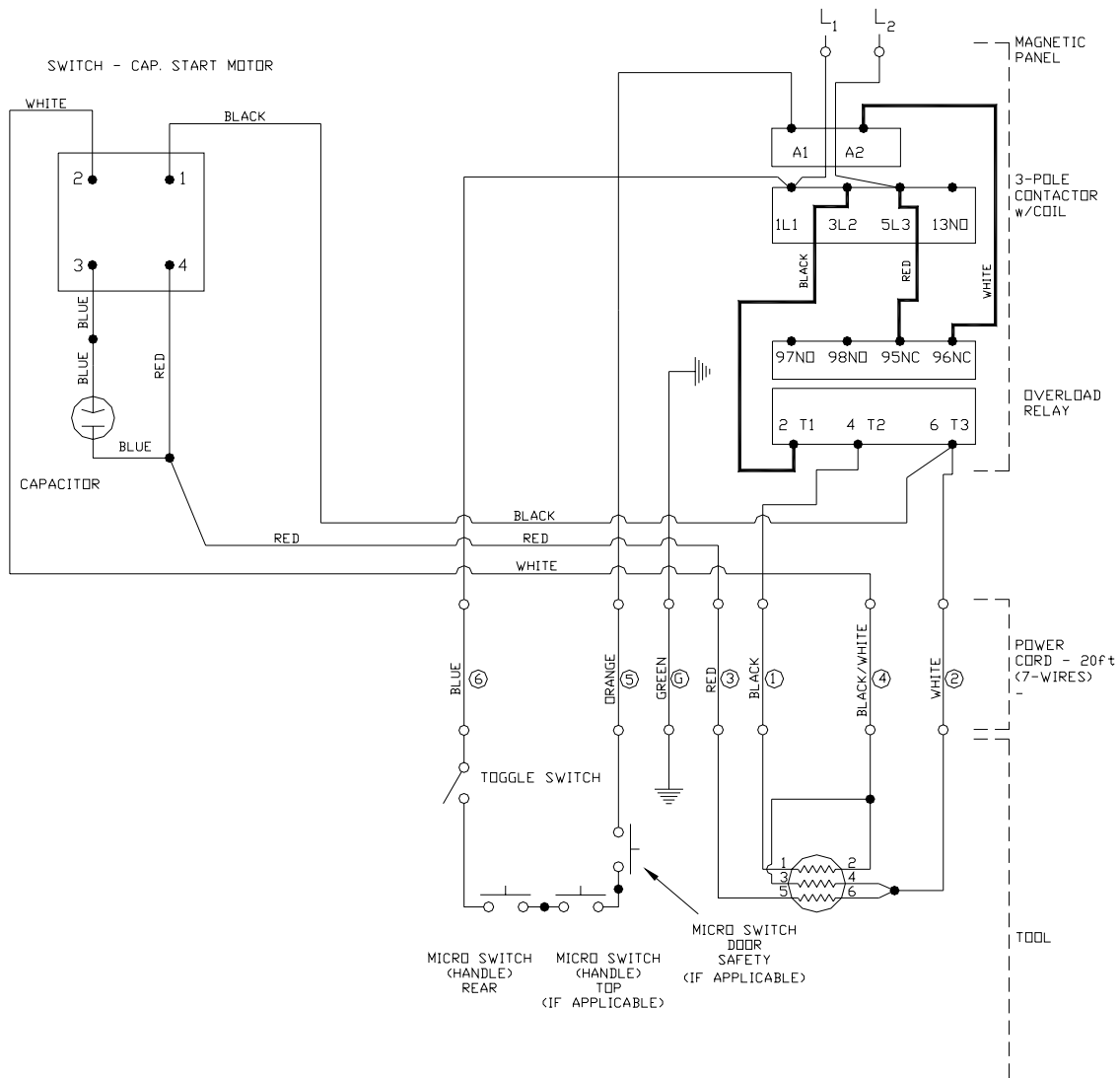

**NOTES:**

1. DO NOT ATTEMPT OR MAKE REPAIRS ON THE MACHINE WHILE POWER IS ON.
2. ALL ELECTRICAL WORK MUST BE PERFORMED BY A QUALIFIED ELECTRICIAN.
3. THE ELECTRICAL DIAGRAM SHOWS THE MACHINE IN THE "OFF" POSITION.
4. THE GROUND WIRE (GREEN) OF THE POWER CABLE IS CONNECTED TO THE FRAME OF THE MACHINE.

**To obtain the correct Kentmaster part number for 3-pole contactor and overload relay, please contact the Kentmaster representative.**

**Figure 13 WIRING DIAGRAM – 230 VOLT, SINGLE PHASE**

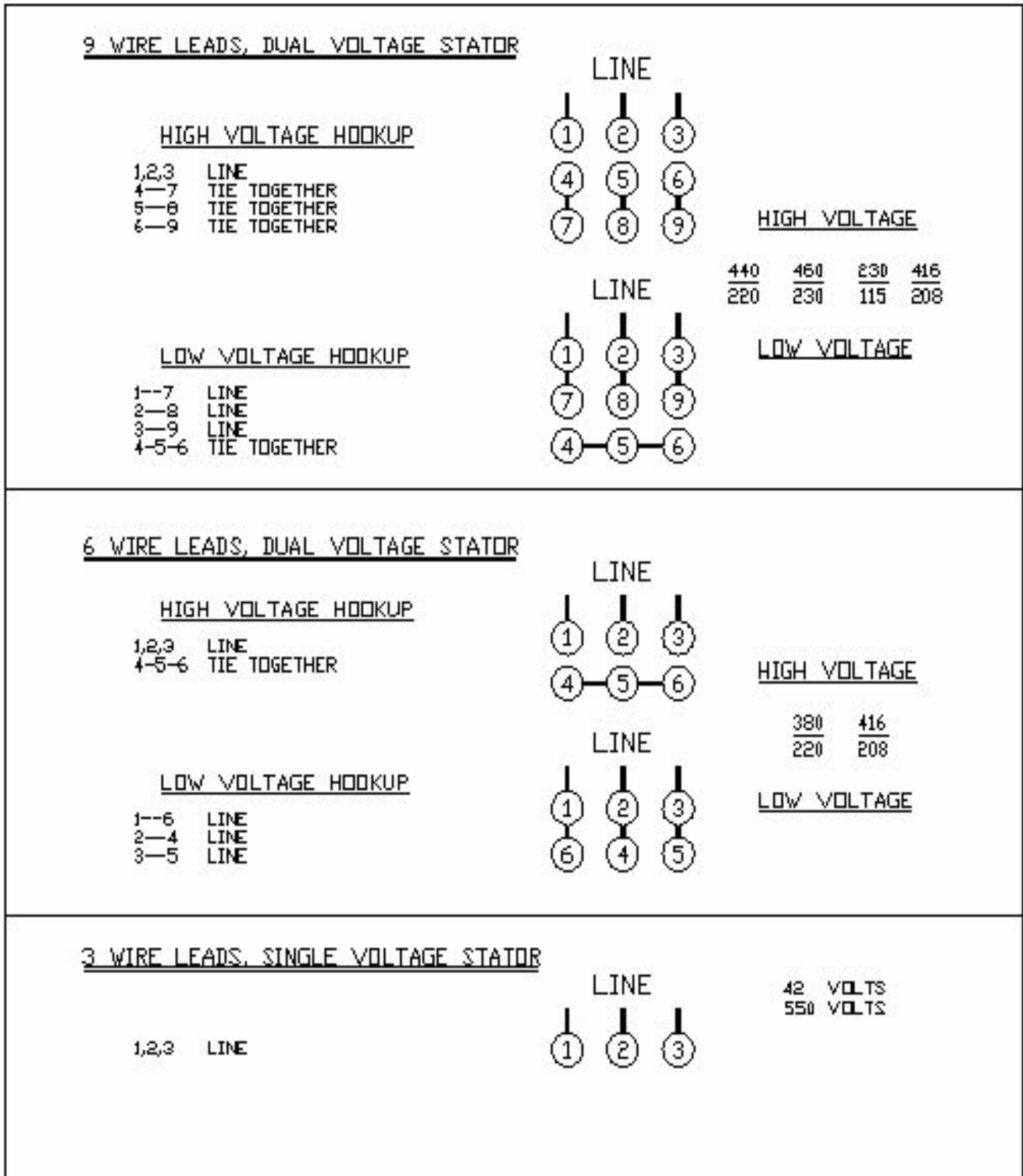

**Figure 14 ELECTRIC MOTOR LEAD HOOKUP DIAGRAM 3 PHASE MOTOR**

[ENGLISH]

## GENERAL INFORMATION

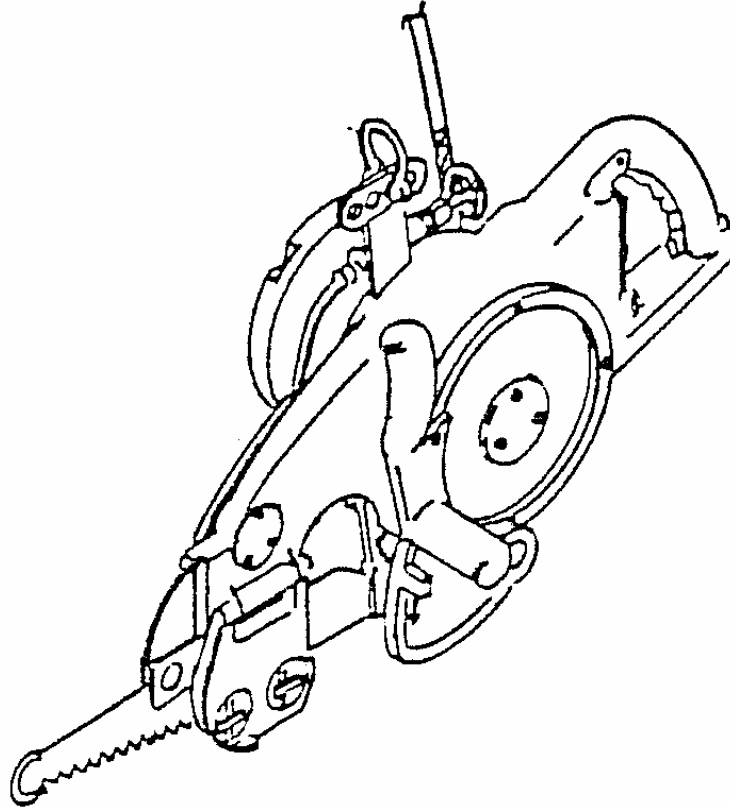

### MODEL

**“153” BEEF BRISKET SAW (1530000)**

---

### SERVICE CENTERS

**KENTMASTER LTD. (U.K)**  
16 AVONBANK INDUSTRIAL CENTRE  
WEST TOWN ROAD  
AVONMOUTH - BRISTOL BS11 9DE  
UNITED KINGDOM

☎ **TELEPHONE: ++ 44- (0) 117- 9235035**  
**FAX: ++ 44- (0) 117- 9829010**

**KENTMASTER MFG. CO., INC.**  
1801 SOUTH MOUNTAIN AVE.  
MONROVIA, CALIFORNIA 91016  
UNITED STATES OF AMERICA

☎ **TELEPHONE: (626) 359-8888**  
**FAX: (626) 303-5151**



**NOTICE TO EMPLOYER AND PURCHASER OF TOOL**  
**NOTICE TO SAFETY DIRECTOR**

**You have purchased a powerful tool that, if misused, can cause severe injury and harm to your employees. You must instruct your employees in the safe and proper use of this tool and to follow the safety procedures and instructions that have been supplied by the manufacturer of this tool. Please follow the following instructions.**

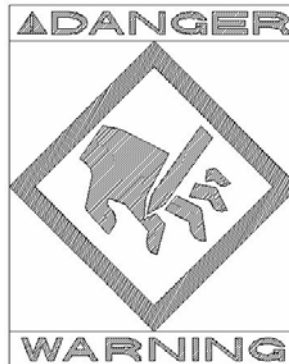

1. Instruct tool operators to test the tool each day before using it to be sure it does not malfunction. Remove and repair any tool that malfunctions.
2. Instruct tool operators to immediately stop using a tool that malfunctions or is defective.
3. Instruct personnel to immediately remove all tools that malfunction. Be sure to disconnect tool from power supply.
4. Instruct all personnel to stay clear of tool, and not to stand or walk in front of, or next to tool when in use.
5. Point out to all personnel the dangers related to the misuse of tool and the importance of following safety procedures and instructions.
6. Do not make, or allow others to make, alterations or modifications to this tool. Replace all lost or illegible labels.
7. Follow all safety, installation and maintenance instructions provided with this tool. Establish proper safety procedures in accordance with local and national requirements to prevent accidental energizing of tool that can cause injuries.
8. If this tool is sold or change in ownership takes place, you must provide the new owner all safety instructions, notices and maintenance instructions you were originally provided. You can obtain additional copies of the instructions from Kentmaster, free of charge upon request.
9. Give copies of instructions to:
  - (A) Tool Operators**
  - (B) Maintenance Supervisor**
  - (C) Clean-up Supervisor**



## GENERAL INFORMATION



COVERING: SAFETY PRECAUTIONS AND PLACING INTO SERVICE  
**ELECTRICAL POWERED BEEF BRISKET SAW**

**READ THIS MANUAL CAREFULLY BEFORE INSTALLING, OPERATING OR SERVICING  
THIS TOOL**

IT IS THE RESPONSIBILITY OF THE EMPLOYER TO PLACE THIS INFORMATION INTO THE HANDS OF THE OPERATOR.

### **PLACING INTO SERVICE**

- |                                                                                                  |                                                                                                                   |
|--------------------------------------------------------------------------------------------------|-------------------------------------------------------------------------------------------------------------------|
|  <b>WARNING</b> | = Hazards or unsafe practices which could result in severe personal injury, death or substantial property damage. |
|  <b>CAUTION</b> | = Hazards or unsafe practices which could result in minor personal injury, product or property damage.            |
|  <b>NOTICE</b>  | = Important installation, operation or maintenance information.                                                   |

- |                                                                                                    |                                                                                                                                                                                                                                                             |
|----------------------------------------------------------------------------------------------------|-------------------------------------------------------------------------------------------------------------------------------------------------------------------------------------------------------------------------------------------------------------|
|  <b>WARNING</b> | Installation, adjustment repair and maintenance of this tool must be made by trained and qualified personnel.                                                                                                                                               |
|  <b>WARNING</b> | Always disconnect power supply from tool before: <ul style="list-style-type: none"> <li>(A) Installing or removing blade from tool.</li> <li>(B) Making repairs or adjustments to the tool.</li> <li>(C) performing maintenance or cleanup work.</li> </ul> |

## INSTALLATION INSTRUCTIONS

 **WARNING** ALL ELECTRICAL WIRING MUST BE DONE BY A LICENSED ELECTRICIAN IN ACCORDANCE WITH THE NATIONAL, STATE AND LOCAL ELECTRICAL CODES. (REFER TO NAMEPLATE ON TOOL FOR PROPER POWER CONFIGURATION).

1. A BALANCER IS REQUIRED FOR OPERATION AND USE OF THIS TOOL. WEIGHT OF TOOL MUST FALL WITHIN WEIGHT RANGE OF BALANCER. "AIR-BALANCERS" WHICH OPERATE ON COMPRESSED AIR, ARE HIGHLY RECOMMENDED FOR USE WITH "153" SAWS. THEY PROVIDE LONG TRAVEL AND VERY SMOOTH, UNIFORM RISE AND FALL. THEY CAN BE INTERFACED WITH THE OPERATION OF THE SAW.
2. INSTALL BALANCER ABOVE WORK AREA. BALANCER MUST HAVE SUFFICIENT VERTICAL TRAVEL SO OPERATOR CAN REACH ENTIRE WORK AREA WITH TOOL WITHOUT STRAIN. "153" SAW SHOULD BE HUNG FROM A RAIL PARALLEL TO THE TROLLEY TRAIL. THE DISTANCE FROM THE RAIL SHOULD BE 20 INCHES.
3. ADJUST BALANCER ACCORDING TO THE OPERATOR'S PREFERENCE AND COMFORT.

 **WARNING** WE STRONGLY SUGGEST THAT AN ADDITIONAL SAFETY CHAIN BE USED TO CHAIN BALANCER TO OVERHEAD TROLLEY. THIS ADDITIONAL MEASURE OF SAFETY WILL HELP REDUCE INJURIES.

## OPERATING INSTRUCTIONS

**⚠ WARNING** ONLY TRAINED PERSONNEL ARE TO OPERATE THIS TOOL.

### MAINTENANCE

**⚠ WARNING** ONLY TRAINED AND QUALIFIED PERSONNEL ARE TO PERFORM MAINTENANCE AND SERVICE TO THIS TOOL.

**OIL LUBRICATION:** THE FAT OF THE CARCASS PROVIDES SUFFICIENT LUBRICATION FOR THE BLADE GUIDES AND OIL LUBRICATION IS NOT NECESSARY WHEN MACHINE IS IN OPERATION. OIL LUBRICATION SHOULD BE APPLIED AT POINTS A, B, AND ROCKER ARM TO PREVENT OXIDATION AND CORROSION AFTER MACHINE HAS BEEN THOROUGHLY CLEANED AT THE END OF A NORMAL DAYS OPERATION, OR WHEN MACHINE IS NOT TO BE USED FOR AN EXTENDED PERIOD OF TIME.

**GREASE LUBRICATION:** GREASE LUBRICATION IS RECOMMENDED TWICE WEEKLY AT POINT C. FOR APPLICATION OF GREASE LUBRICANT AT POINT E, GREASE FITTING IS ACCESSIBLE FROM THE MOTOR SIDE OF THE MACHINE. LUBRICATION OF POINT DESCRIBED ABOVE WILL INSURE PROPER OPERATION AND LONG BEARING LIFE OF YOUR "KENTMASTER 153 BEEF SPLITTING SAW".

**CAUTION: DO NOT OVER GREASE.**

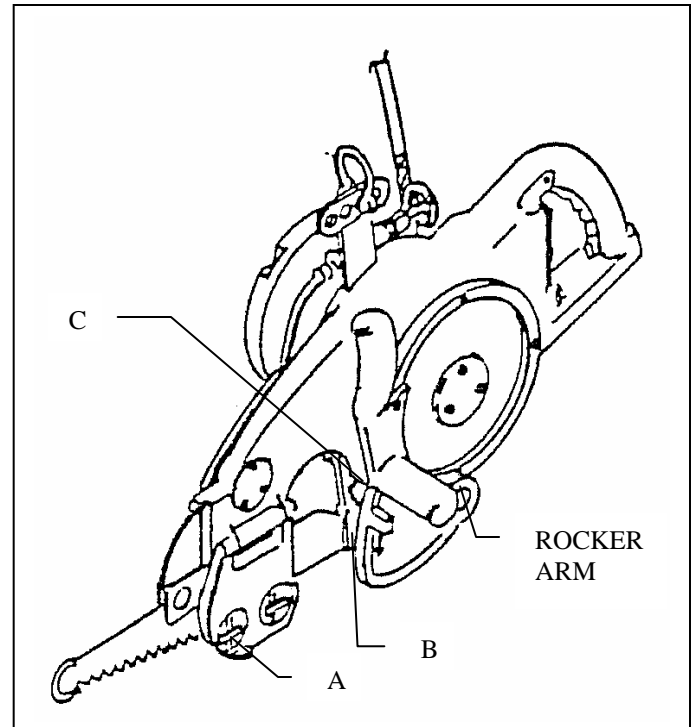

RECOMMENDED BEARING GREASE LUBRICANT CAN BE PURCHASED FROM "KENTMASTER MFG., CO., INC."

### BLADE REMOVAL AND CLEANING.

**⚠ WARNING** ALWAYS DISCONNECT POWER SUPPLY FROM TOOL BEFORE INSTALLING OR REMOVING BLADE FROM TOOL.

**⚠ WARNING** ALWAYS WEAR WIRE MESH GLOVES WHEN INSTALLING OR REMOVING BLADES FROM TOOL.

TO INSTALL SAW BLADE, ROTATE 1500560 GUARD – ROCKER ARM TO THE OPEN POSITION. UNLOCK 1500290 COVER – BLADE SLIDE BY PUSHING IN ON 1501030 PUSH KNOB AND TURNING 1501020 TURN BOLT PARALLEL TO SLOT ON 1500290 COVER. OPEN COVER – BLADE SLIDE AND MOUNT SAW BLADE ON 1500430 ROLLER – SUSPENSION ARM. INSERT OPPOSITE END OF SAW BLADE INTO THE SLOT OF 1500080 ROCKER ARM AND ALIGN HOLES OF ROCKER ARM AND SAW BLADE. INSERT 1500320 BLADE PIN THROUGH BOTH PARTS. PULL BACK ON 1500310 SPRING AND SNAP IT INTO THE GROVE OF BLADE PIN. CLOSE 1500290 COVER AND LOCK BY TURNING 1501020 TURN BOLT ¼ TURN. TO REMOVE SAW BLADE FROM THE MACHINE, FOLLOW ABOVE PROCEDURE IN REVERSE.

**DECLARATION OF CONFORMITY**

**DECLARATION OF CONFORMITY**

DECLARATION DE CONFORMITE -DECLARACION DE CONFORMIDAD- ERKLARUNG BEZUGLICH EINHALTUNG DER VORSCHRIFTEN  
DICHIARAZIONE DI CONFORMITA . CONFORMITEITSVERKLARING

**MANUFACTURED BY:**

FABRIQUE PAR:  
FABRICADA POR:  
HERGESTELLTVON:  
FABBRICATO DA:  
VERVAARDIGD DOOR:

**KENTMASTER MFG CO., INC.**  
**1801 SOUTH MOUNTAIN AVE.**  
**MONROVIA, CALIFORNIA 91016**  
**UNITED STATES OF AMERICA**  
**TELEPHONE (626) 359-8888 FAX (626) 303-5151**

**TYPE / SERIES: BEEF BRISKET SAW**

TYPE / SERIE:  
TIPO / SERIE:  
TYP / SERIE:  
TIPO / SERIE:  
TYPE / SERIE:

**MODEL: 153**

MODELE:  
MODELO:  
MODELL:  
MODELLO:  
MODEL:

**SERIAL NO. RANGE: XXXXX**

N SERIE: • GAMA DE No. DE SERIE: • SERIEN-NR.-BEREICH: • NUMERI DI SERIE: • SERIENUMMERS:

**This product complies with the following European Community Directives:**

Ce produit est conforme aux directives de la Communaute europeenne suivantes:  
Este producto cumple con las siguientes Directrices de la Comunidad Europea:  
Dieses Produkt erfult die folgenden Vorschriften der Europaischen Gemeinschaft:  
Questo prodotto e conforme alle seguenti direttive CEE:  
Dit produkt voldoet aan de volgende EG-richtlijnen:

**89/392/EEC, 91/368/EEC, 93/44/EEC, 93/68/EEC**

**The following Standards were used to verify compliance with the Directives:**

Les normes suivantes ont ete utilisees pour verifier la conformite avec les Directives:  
Las siguientes Normas se usaron para verificar el cumplimiento de las Directrices:  
Folgende Normen wurden angewandt, um erfullung der vorschriften zu bestatigen:  
Per verificare la conformita del prodotto alle direttive sono stati usati i seguenti standard:  
De volgende normen zijn gebruikt om naleving van de richtlijnen te bevestigen:

**EN 292**

**Approved by:** \_\_\_\_\_

**Date:** AUG - 1 - 1995

RALPH KARUBIAN MONROVIA, CA. U.S.A  
(Engineering Manager) (Directeur technique) (gerente de ingenieria) (verantwortlicher Konstruktionsleiter) (Responsabile tecnico) (ondersteunend technisch mangan)

## Kentmaster Worldwide Location

Kentmaster Equipment (Aust) PTY.LTD.

Unit 2,24 Central Court  
Browns Plains Qld. 4118  
Australia

Telephone: (07) 3806-8400

Fax: (07) 3806-7933

[Australia@Kentmaster.com](mailto:Australia@Kentmaster.com)

---

Kentmaster do Brasil, Ltda.

Av. Dr. Joao Teodoro No. 805  
Bairro De Vila Rezende  
13405-240 Piracicaba, SP,  
Brazil

Telephone #1: (019) 3 413 3113

Telephone #2: (019)983-4973

Fax: (019) 3 413 3113

[Brazil@Kentmaster.com](mailto:Brazil@Kentmaster.com)

---

Kentmaster (IRL) LTD.

Benamore, Dublin Road.  
Roscrea,  
CO, Tipperary,  
Ireland

Telephone: (353) 0505-23292

Fax: (353) 0505-23299

[Ireland@Kentmaster.com](mailto:Ireland@Kentmaster.com)

---

Kentmaster Equipment (NZ) LTD.

5 Cooper Street  
Havelock North  
New Zealand

Telephone #1: (64) 6 8777 857

Telephone #2: 0800 KENTMASTER

Fax: (64) 6 8777 858

[NewZealand@Kentmaster.com](mailto:NewZealand@Kentmaster.com)

---

Kentmaster South Africa (PTY) LTD.

Johannesburg - S. Africa  
Unit 54 Sunnyrock Park  
Sunrock Close, Germiston  
South Africa

Telephone: (27) 11-455-3748

Fax: (27) 11-455-3749

[SouthAfrica@Kentmaster.com](mailto:SouthAfrica@Kentmaster.com)

---

Kentmaster (UK ) LTD.

Unit 16 Avonbank Ind. Centre  
West Town Rd, Avonmouth-Bristol,  
BS11 9DE  
England

Telephone: (44) 117-923-5035

Fax: (44)-117-932-9010

[UK@Kentmaster.com](mailto:UK@Kentmaster.com)

---

Kentmaster Mfg. Co., Inc.

1801 South Mountain Ave.  
Monrovia, CA, 91016  
USA

Telephone #1: (626) 359-8888

Telephone #2: (800) 421-1477

Fax: (626) 303-5151

[info@Kentmaster.com](mailto:info@Kentmaster.com)

---

Kentmaster Omaha

4417 South 139th Street  
Omaha, NE, 68137  
USA

Telephone #1: (402) 896-3355

Telephone #2: (800) 367-3181

Fax: (402) 896-3311

[Omaha@Kentmaster.com](mailto:Omaha@Kentmaster.com)

---

**INDEX**

**OPERATING AND SAFETY INSTRUCTIONS**..... 2

**SERVICE** ..... 3

**PARTS BOOK**..... 3

**“153” MAIN ASSEMBLY** ..... 3

**MOTOR ASSEMBLY** ..... 5

**POWER SUPPLY** ..... 6

**WIRING DIAGRAMS** ..... 11

        3-PHASE, DIFFERENT CONTROL AND MOTOR VOLTAGE ..... 11

        3-PHASE, SAME CONTROL AND MOTOR VOLTAGE..... 12

        SINGLE PHASE, 115 VOLT ..... 13

        SINGLE PHASE, 230 VOLT ..... 14

**GENERAL INFORMATION** ..... 18

**INSTALLATION INSTRUCTIONS** ..... 18

**OPERATING INSTRUCTIONS**..... 19

**MAINTENANCE**..... 19

**DECLARATION OF CONFORMITY**..... 20

*Kentmaster Worldwide Location* ..... 21

**INDEX**..... 22

**FIGURES - INDEX**..... 22

**FIGURES - INDEX**

Figure 1 MODEL “153” ..... 4

Figure 2 MOTOR ASSEMBLY ..... 5

Figure 3 1002420: POWER SUPPLY, NON 42V, 3 PHASE..... 6

Figure 4 1002430: POWER SUPPLY, 42V, 3 PHASE ..... 6

Figure 5 POWER SUPPLY, 115V, SINGLE PHASE ..... 7

Figure 6 POWER SUPPLY, 230V, SINGLE PHASE SWITCH ASSEMBLY ..... 7

Figure 7 1502140: SWITCH PLATE ASSEMBLY ..... 8

Figure 8 1501960: ROCKER ARM..... 9

Figure 9 1501940: SUSPENSION ARM..... 10

Figure 10 WIRING DIAGRAM – different control and motor voltage ..... 11

Figure 11 WIRING DIAGRAM – same control and motor voltage..... 12

Figure 12 WIRING DIAGRAM – 115 VOLT, SINGLE PHASE..... 13

Figure 13 WIRING DIAGRAM – 230 VOLT, SINGLE PHASE..... 14

Figure 14 ELECTRIC MOTOR LEAD HOOKUP DIAGRAM 3 PHASE MOTOR ..... 15